

C6121ZG57a 型 柴 油 机 零 件 目 录

PARTS CATALOG OF C6121ZG57a DIESEL ENGINE

скачано с сайта
specinter.ru



上海柴油机股份有限公司
SHANGHAI DIESEL ENGINE CO.,LTD.
2008.8

使 用 说 明

随着 C6121 系列柴油机产量的不断提高和变型产品的逐步增加，各变型柴油机的零部件的品种也随之增加，为适应广大用户选购 C6121ZG57a 型柴油机备件的需求，特编制本零件目录以供用户使用。

本零件目录册如有不当之处，敬请广大用户批评指正。

скачано с сайта
specinter.ru

编者

2008.8

组件名称\组件件号\柴油机型号 NAME\ NO.\ENGINE MODEL	C6121ZG57a
机体组件 / BLOCK GP-CYLINDER	8N5286
机体盖板组件 / COVER GP (BLOCK-MISE)	02BZ006
曲轴油封组件 / SEAL GP-CRANKSHAFT	2P6226
加油口组件 /FILLER GP-OIL	2P6855
曲轴后油封座组件/SUPPORT GP-REARSEAL CSHAFT	02EZ001
油底壳组件 / PAN GP-OIL	2P6152
油底壳紧固组件 / FASTENER GP (OIL PAN)	2P6206
油尺组件 / GAGE GP-OIL LEVEL	2P6493
气缸盖组件 / HEAD GP-CYLINDER (A)	7N8876
气缸盖盖板组件/ COVER GP	2P6531
气缸盖紧固组件/FASTENER GP	7N9536
发动机起吊组件 / LIFTING GP-ENGINE	7N7858

组件名称\组件件号\柴油机型号 NAME\ NO.\ENGINE MODEL	C6121ZG57a
活塞连杆组件 / PISTON & GP-ROD	05AZ501
曲轴组件 / CRANKSHAFT GP	06AZ102
曲轴皮带轮组件 / PULLEY GP-CRANKSHAFT	06BZ007
飞轮组件 / FLYWHEEL GP	06CZ002
减震器组件 / DAMPER GP	9N2345
定时齿轮组件 / GEAR GP-FRONT	07AZ202
消声器组件 / MUFFLER GP	08AZ022
排气引射器组件 / EXTENSION GP EXHAUST	7S1784
凸轮轴组件 / CAMSHAFT GP	1N4406
起动机组件 / MOTOR GP	11AZ003
充电发电机组件/ALTERNATOR GP	11BZ009
进气管路组件 / LINES GP-AIR	12AZ009

组件名称\组件件号\柴油机型号 NAME\ NO.\ENGINE MODEL	C6121ZG57a
进排气管路组件 / LINES GP-AIR	12BZ016
排气歧管组件 / MANIFOLD GP-EXHAUST	2P6573
排气管紧固组件/FASTENER GP	8N1868
空气滤清器组件 / CLEANER GP-AIR	14AZ007
机油泵组件(双节)/ PUMP GP-ENGINE OIL	2P1784
风扇支架组件 / DRIVE GP-FAN	16AZ009
风扇皮带轮组件 / PULLEY GP-(FAN)	16BZ015
三角带组件 / VEE BELT SET(SEE NOTE)	16CZ008

组件名称\组件件号\柴油机型号 NAME\ NO.\ENGINE MODEL	C6121ZG57a
风扇及防护罩组件/ FAN & GUARD GP	16DZ009
机油冷却器和滤清器组件/COOLER&FILTER GP-OIL	18AZ009
传动装置油冷却器组件 / COOLER GP- OIL	18BZ007
机油管路组件 / LINES GP-ENGINE OIL	2P6105
增压器机油管路组件/LINES GP-TURBOCHARGER OIL	19BZ202
水泵组件 / PUMP GP-WATER	7N5909
调温器组件 / REGULATOR & GP-HOUSING	1W7553
冷却水管路组件 / LINES GP-WATER	2W6779

组件名称\组件件号\柴油机型号 NAME\ NO.\ENGINE MODEL	C6121ZG57a
喷油管路组件 / LINES GP-FUEL INJECTION	26AZ201
燃油管路组件 / LINES GP-DRAIN	26BZ203
发动机支架组件 / SUPPORT GP-ENGINE	33AZ012
电磁切断器组件 / SHUT-OFF GP-ELECTRICAL	59AZ212
前齿壳组件 / HOUSING GP-FRONT	8N0303
前齿壳盖板组件 / COVER GP (FRONT HOUSING)	2P6528
前齿壳紧固组件 / FASTENER GP (FRONT HOUSING)	8N0872
前油封座组件(耳轴) / TRUNNION GP	7N9589
气门机构组件 / MECHANISM GP-VALVE	7N8026
气缸盖罩壳组件 / COVER GP-VALVE MECHANISM	8N4745
通风帽组件 / BREATHER GP	1P4244
通气管组件 / DISPOSAL GP-FUMES	84DZ003

组件名称\组件件号\柴油机型号 NAME\ NO. \ENGINE MODEL	C6121ZG57a
增压器组件 / TURBOCHARGER GP	38AZ005
喷油泵调速器组件 / PUMP GP-GOV	P10Z005
变型配套及其它组件 / APPLICATION GP	00AZ214
燃油滤清器组件 / FILTER GP-SECONDARY	85AZ203
随机工具组件 / TOOLS GP	49AZ002

скачано с сайта
specinter.ru

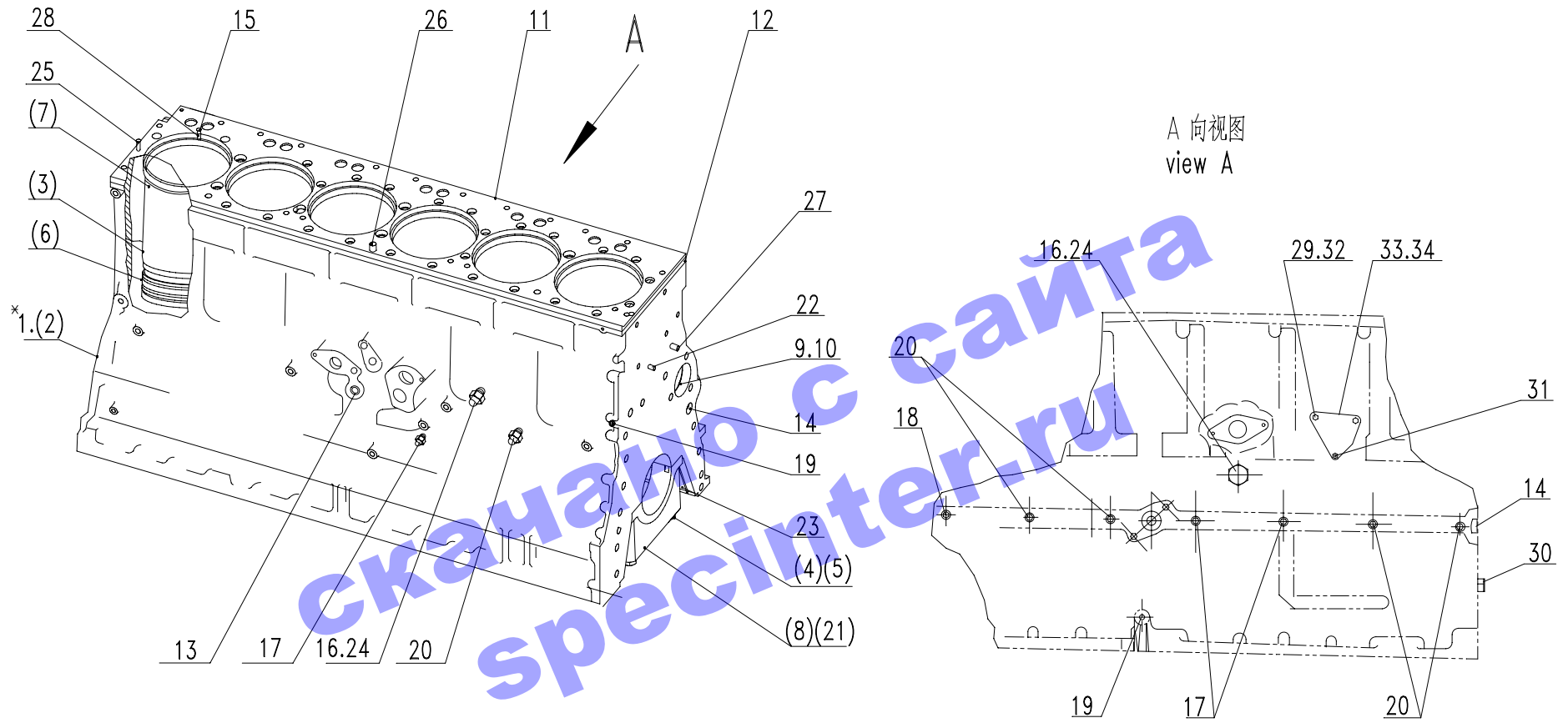

8N5286 02BZ006

图1 机体组件零部件、机体盖板组件零部件
 FIG.1 BLOCK GP-CYLINDER、COVER GP(BLOCK-MISE)

图 1：机体组件和机体盖板组件零部件/ Fig. 1:BLOCK AND COVER GP

标号 Ref. No	名称 NAME	件号 PART No.	数量 Quantity	
			8N5286	02BZ006
*1	机体装配部件/BLOCK AS.-CYLINDER	7N6550	1	
(2)	机体/BLOCK AS-CYLINDER	4P0623	1	
(3)	气缸套/LINER-CYLINDER	1105800 (2P8889)	6	
(4)	主轴承盖 (第 1-6 档) CAP-CRANKSHAFT BEARING	6N8001	6	
(5)	推力主轴承盖 (第 7 档) CAP-CRANKSHAFT BEARING	6N8002	1	
(6)	O 形密封圈/SEAL-O-RING	5S6670(117.1×4.39)	18	
(7)	密封带/BAND-FILLER	2W6134	6	
(8)	主轴承盖螺栓/BOLT	7S3224(5/8-11×133.35)	14	
9	凸轮轴轴套 (第 2-5 档) /BEARING	7M4046	4	
10	凸轮轴前轴套 (第 1 档) /BEARING	8N4110	1	
11	机体顶板/PLATE	7N7998(1W1410)	1	
12	机体顶板垫片/GASKET-PLATE	7W7546(1157550)	1	
13	碗形闷头/PLUG	4B5387	1	
14	碗形闷头/PLUG	3B0623	1	1
15	空心圆柱销/DOWEL	1S9540(9.368×30.2)	1	
16	六角螺塞/PLUG	8M9307(1/2-13)	1	
17	内方锥管螺塞 PLUG-PIPE(SQUARE COUNTERSUNK)	2B0858(1/2-14)	3	
18	内六角锥管螺塞 PLUG-PIPE(HEX COUNTERSUNK)	7H3171(1/4-18)	1	
19	六角锥管螺塞/PLUG-PIPE	5M6214(1/8-27)	1	
20	六角锥管螺塞/PLUG-PIPE	5M6213(1/4-18)	4	
(21)	硬垫圈/WASHER	2S5658(17×29×3)	14	
22	双头螺栓/STUD	5S8462(3/8-24)	1	
23	钢球/STEEL SPHERE	GB/T308-9.5250	1	
24	铜垫圈/WASHER	6F7062(12.7×19.0×1.8)	1	
25	圆柱销/PIN	8K1207(9.368×32.00)	2	

图 1：机体组件和机体盖板组件零部件/ Fig. 1:BLOCK AND COVER GP

标号 Ref. No	名 称 NAME	件号 PART No.	数量 Quantity	
			8N5286	02BZ006
26	圆柱销/DOWEL	5B7652(15.716×15.75)	2	
27	圆柱销/DOWEL	8B6349(15.718×35.00)	2	
28	O 型密封圈/SEAL	3S5496(9.53×4.3)	1	
29	平垫圈/WASHER	5M2894(10.2×18.5×2.5)		2
30	圆柱销/DOWEL	362A001(15.718×56)		2
31	内六角沉头螺钉/BOLT	8M3267(3/8-16×13.05)		1
32	六角头螺栓/BOLT	0L1351(3/8-16×22.22)		2
33	盖板/COVER	8L8662		1
34	垫片/WASHER	5S8055		1

*1: 机体装配部件中包括标号为 (2) …… (8) (21) *1: BLOCK AS.-Cylinder includes parts of Ref.No.(2)...(8)、(21).

скачан с сайта
specinter.ru

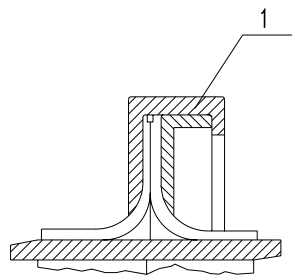

B处曲轴后油封(双唇)
detail B

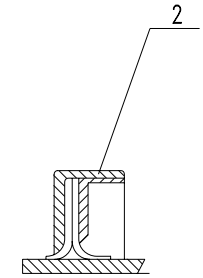

A处曲轴前油封
detail A



图2 曲轴油封组件零部件
FIG.2 SEAL GP-CRANKSHAFT

图 2: 曲轴油封部件零部件/ Fig. 2: SEAL GP-CRANKSHAFT

标号 Ref No.	名 称 NAME	件号 PART No.	数量 Quantity
			2P6226
1	曲轴后油封部件(双唇) SEAL GP-CRANKSHAFT (A) (CCW ROT)	7C3628(7C4297)	1
2	曲轴前油封部件 SEAL GP-CRANKSHAFT (A) (CW ROT)	9Y9895	1

скачано с сайта
specinter.ru

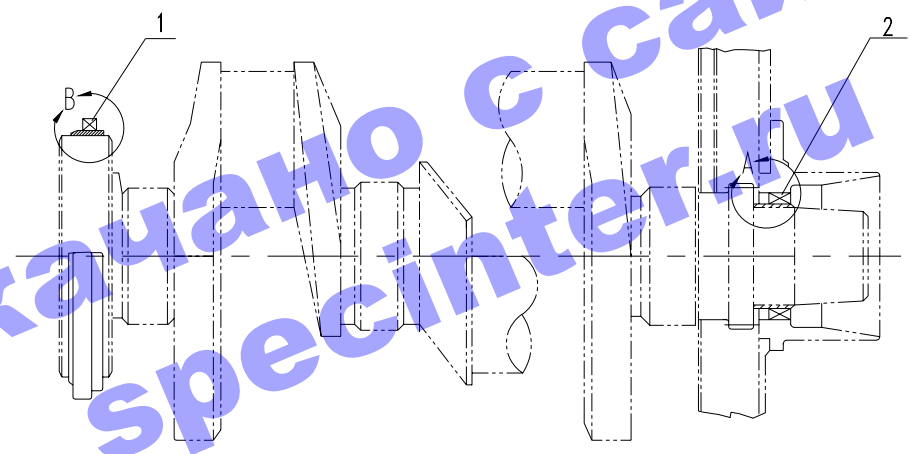
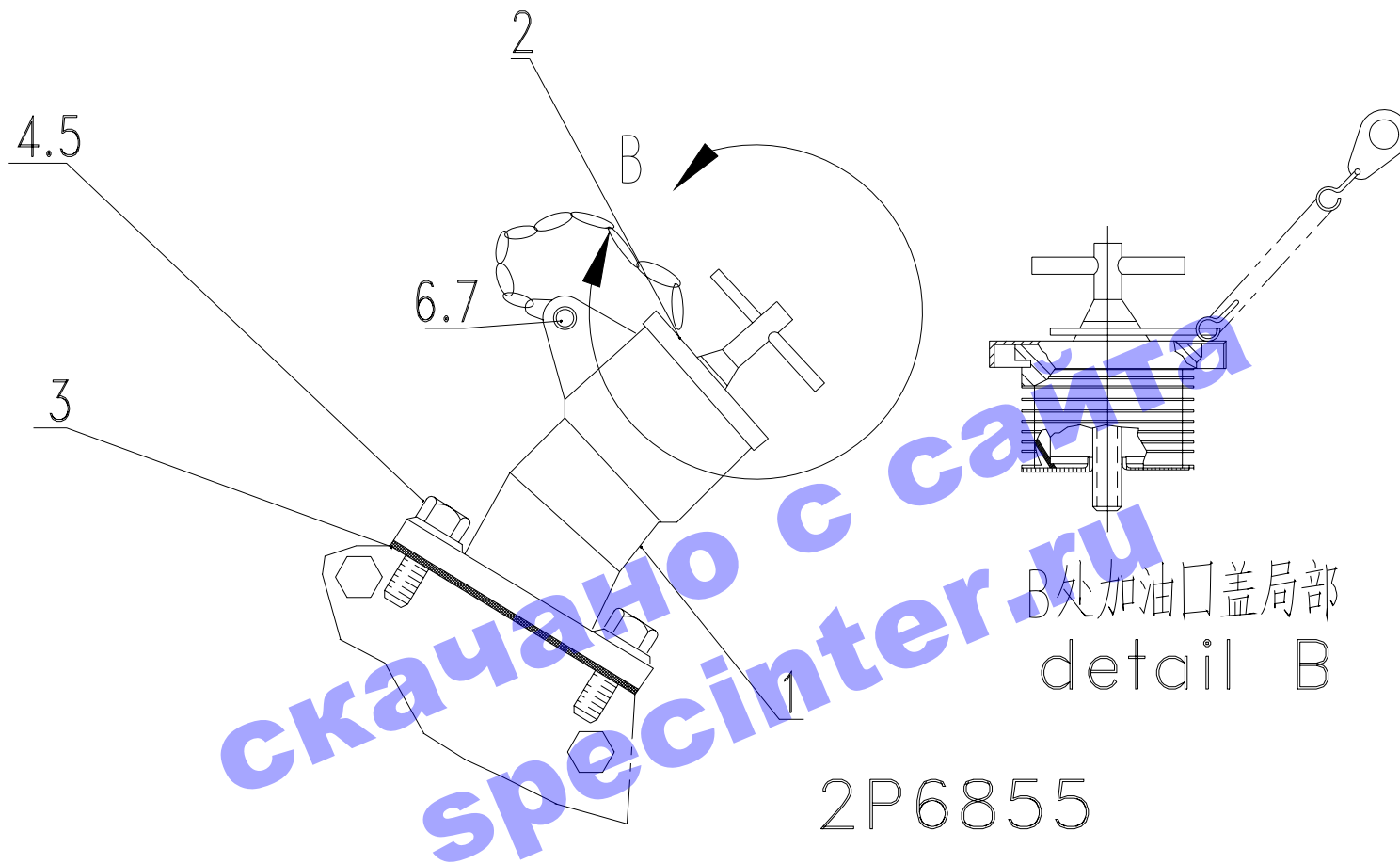

B处加油口盖局部
detail B

2P6855

图3 加油口组件零部件

FIG.3 FILLER GP-OIL

图 3:加油口组件零部件/ Fig. 3: FILLER GP-OIL

标号 Ref. No.	名 称 NAME	件号 PART No.	数量 Quantity
			2P6855
1	加油管/PIPE-OIL FILLER	2P2719	1
2	加油盖部件/CAP AS. -OIL FILLER	6N2985	1
3	垫片/WASHER	2P2720	1
4	六角头螺栓/BOLT	1A2029(3/8-16×28.58)	2
5	垫圈/WASHER	5M2894(10.2×18.5×2.5)	2
6	铆钉/RIVET	GB/T875-5×10-Zn.D	1
7	垫圈/WASHER	GB/T97.1-5-200HV	1

скачано с сайта
specinter.ru



图4 曲轴后油封座组件

FIG.4 SUPPORT GP-REARSEAL CSHAFT

图 4: 曲轴后油封座组件/ Fig4: SUPPORT GP-REARSEAL CSHAFT

标号 Ref. No	名称 NAME	件号 PART No.	数量 Quantity
			02EZ001
1	后油封座/TRUNNION	02EL004a	1
2	隔圈/SPACER	02EL005	4
	隔圈/SPACER	02EL006	9
3	垫片/GASKET	02EL007	1
4	飞轮壳垫片/GASKET	9H5921	1
5	六角头螺栓/BOLT	1A5822(1/2-13×69.85)	4
6	六角头螺栓/BOLT	311A004(1/2-13×88.9)	9
7	O型密封圈/SEAL-O-RING	9M5894(202.56×5.33)	1

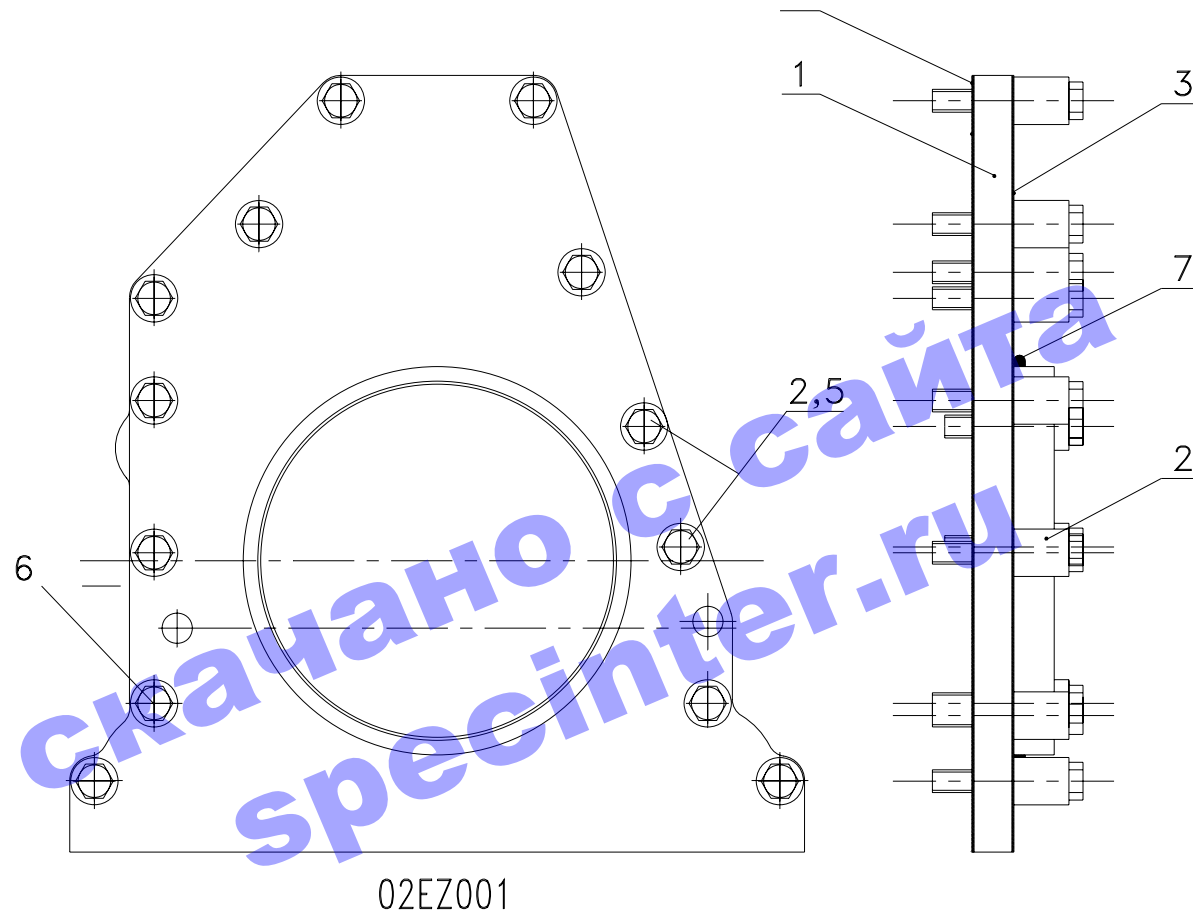
скачано с сайта
specinter.ru



图5 油底壳组件和油底壳紧固组件零部件

FIG.5 PAN AND FASTENER GP

图 5: 油底壳组件和油底壳紧固组件零部件/ Fig. 5: PAN AND FASTENER GP

标号 Ref. No	名 称 NAME	件号 PART No.	数量 Quantity	
			2P6152	2P6206
1	油底壳垫片/GASKET	4M2969	1	
2	油盘垫片/GASKET	8S1965	1	
3	油底壳垫板焊接部件/PLATE AS.	2P1738	1	
4	油盘/PAN GP-OIL(BASIC)	8S6086	1	
5	放油螺塞/PLUG	5N8780	1	
6	六角头螺栓/BOLT	0L1352(3/8-16×82.55)		3
7	垫圈/WASHER	5M2894(10.2×18.5×2.5)		46
8	六角头螺栓/BOLT	0L1351(3/8-16×22.22)		18
9	六角头螺栓/BOLT	0T0573(3/8-16×69.85)		5
10	六角头螺栓/BOLT	0S1591(3/8-16×38.1)		20

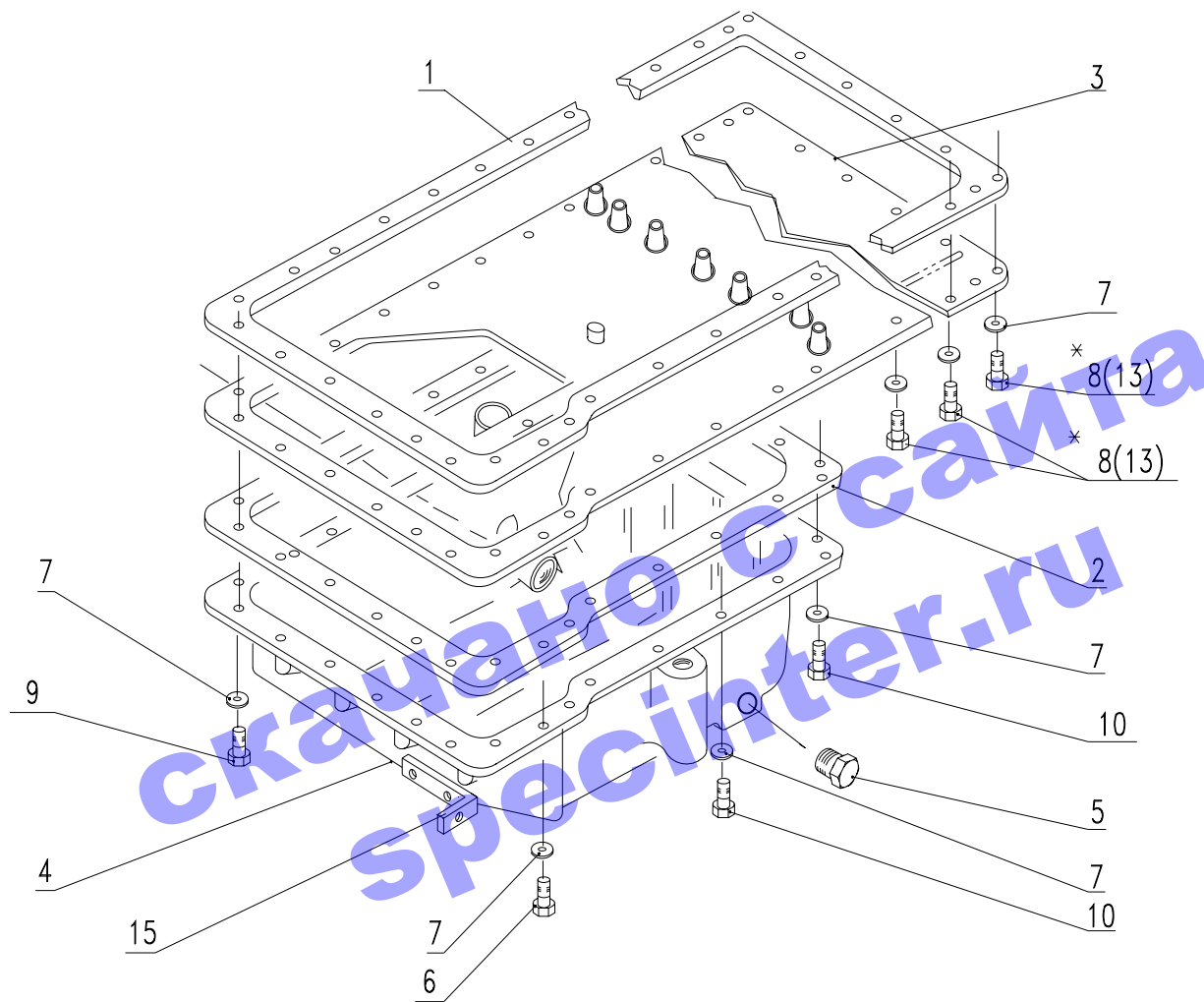
скачано с сайта
specinter.ru

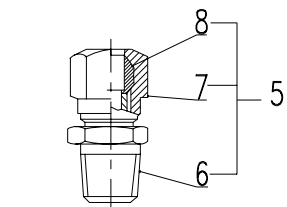

B处局部放大示意图
detail B

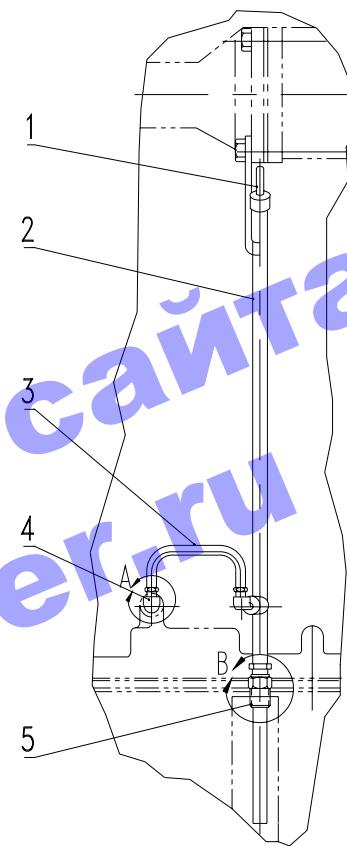

2P6493

图6 油尺组件零部件

FIG.6 GAGE GP-OIL LEVEL

图 6: 油尺组件零部件/ Fig. 6: GAGE GP-OIL LEVEL

标号 Ref.No.	名称 NAME	件号 PART No.	数量 Quantity
			2P6493
1*	油尺焊接部件/GAGE AS.	03CB008 (8S3995)	1
2	油尺管焊接部件/TUBE AS.	2P2547	1
3	通气管部件/TUBE AS.	2P2697	1
4	90° 弯管接头/ELBOW	5K9243	2
*5	管接头装配部件/CONNECTR AS.	8S1326	1
(6)	管接头/CONNECTOR-AIR BRAKE-SPL	5P4908	1
(7)	管接螺母/NUT-AIR BRAKE	5P4448	1
(8)	密封套/SLEEVE-AIR BRAKE	5P4443	1

1*:8S3995 is used for export.

скачано с сайта
specinter.ru



图7.1 气缸盖、气缸盖盖板、气缸盖紧固组件及发动机起吊组件零部件

FIG.7.1 HEAD、COVER、FASTENER AND LIFTING GP

图 7:气缸盖组件、气缸盖盖板组件、气缸盖紧固和发动机起吊组件零部件

Fig. 7: HEAD、COVER、FASTENER AND LIFTING GP

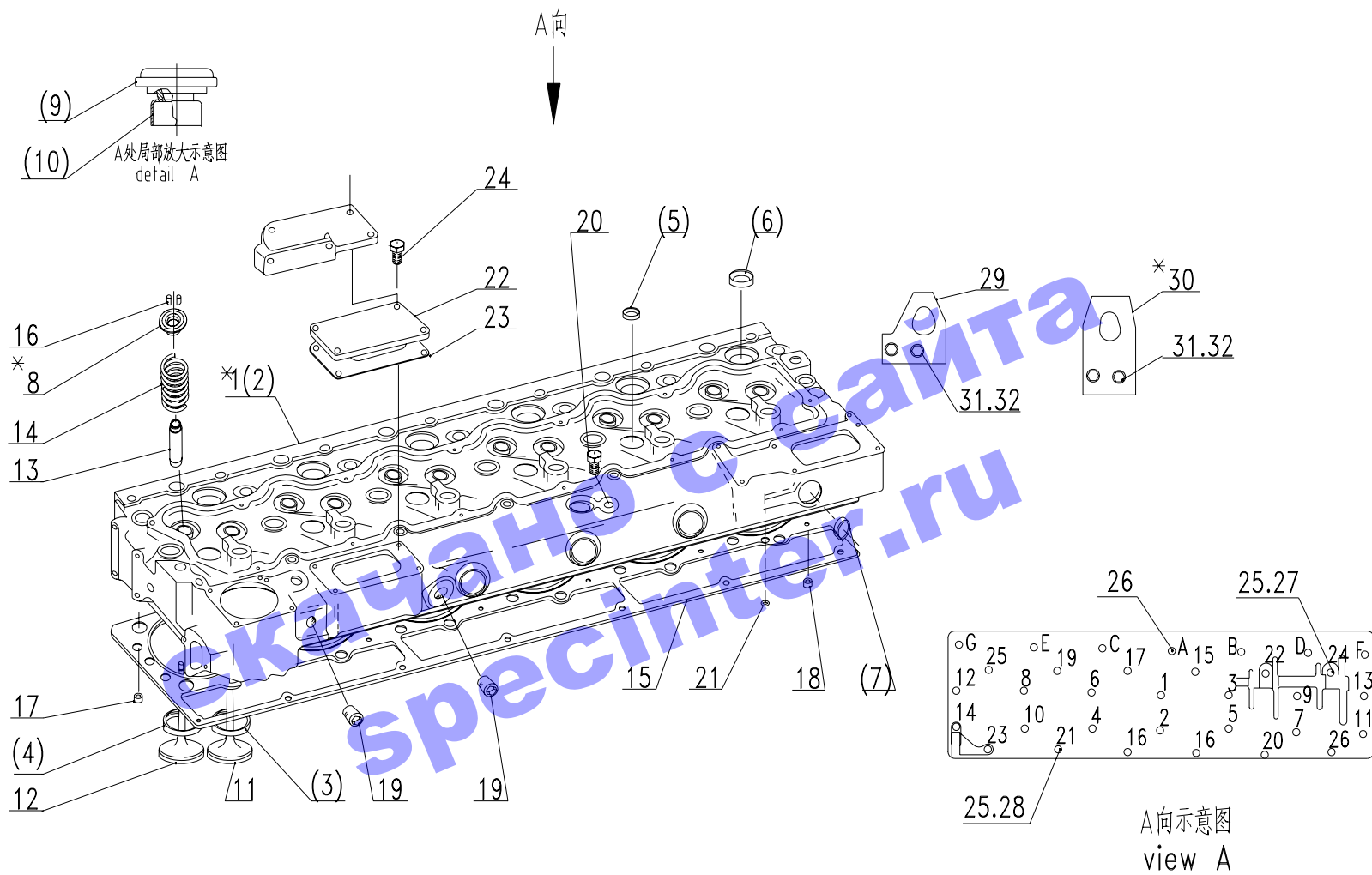
标号 Ref.No.	名称 NAME	件号 PART No.	数量 Quantity			
			7N8876	7N9536	2P6531	7N7858
*1	气缸盖机加工部件/HEAD AS.	7N8866	1			
(2)	气缸盖/HEAD-CYLINDER	7C3906	1			
(3)	进气门座 INSERT-VALVE SEAT (INLET)	7N4448	6			
(4)	排气门座 INSERT-VALVE SEAT (OUTLET)	7N8855	6			
(5)	碗型闷头/PLUG	3B0623	6			
(6)	碗型闷头/PLUG	3P1896	13			
(7)	碗型闷头/PLUG	3S8313	7			
*8	旋转弹簧座及挡油罩部件 ROTOCOIL AS.	1W5300	12			
(9)	旋转弹簧座部件 ROTOCOIL ASSEMBLY (BASIC)	8N7782	12			
(10)	挡油罩/SHIELD-OIL	6N7174	12			
11	进气门/VALVE	6N9915	6			
12	排气门/VALVE	6N9916	6			
13	气门导管/GUIDE	1487425	12			
14	气门弹簧/SPRING	7S7144	12			
15	气缸盖垫片/GASKET	7E6167	1			
16	气门锁夹/LOCK	2A4429	24			
17	封水圈/SEAL-WATER	9Y1798	18			
18	封水圈/SEAL-WATER	7N8018	6			
19	内方头锥管螺塞 PLUG-PIPE (SQUARECOUNTERSUK)	2B0858	3			

*1: 气缸盖机加工部件中包括标号为 (2)……(7) 的零件/*1: Head-Cylinder AS. includes parts of Ref.No.(2)……(7).

*8: 旋转弹簧座及挡油罩部件中标号为 (9)、(10) 的零部件/*8: Rotocoil AS. and Oil Retain Housing includes parts of Ref.No.(9)、(10).

图 7:气缸盖组件、气缸盖盖板组件、气缸盖紧固和发动机起吊组件零部件

Fig. 7: HEAD、COVER、FASTENER AND LIFTING GP

标号 Ref. No.	名称 NAME	件号 PART No.	数量 Quantity			
			7N8876	7N9536	2P6531	7N7858
20	六角锥管螺塞 PLUG-PIPE (HEX COUNTERSUNK)	5M6213	1			
21	O 型密封圈/SEAL-O-RING	3S5496	1			
22	进气管盖板/COVER	1P6758			1	
23	垫片/WASHER	5S6735			1	
24	六角头螺栓/BOLT	0S1588			4	
25	垫圈/WASHER	2S0736		25		
26	气缸盖螺栓/BOLT	5B9603		7		
27	气缸盖螺栓/BOLT	1B7709		5		
28	气缸盖螺栓/BOLT	1D4595		20		
29	后起吊板/PLATE	8N8722				1
*30	前起吊板/PLATE	8N8721				1
31	特种螺栓/BOLT	6V1999				4
*32	硬垫圈/WASHER	8D5054				4

*30: 8N8721 起吊板在 6N8336 组件中置于发动机前端面/*30: Lifting PLATE 8N8721 is ASsembled on the surface of Engine fore-side in Gp. 6N8336.

*32: 4W8652 起吊板在 6N8336 组件中置于发动机前端面/*32: Lifting PLATE 4W8652 is on the surface of Engine back-side in GP. 6N8336.



图8 活塞连杆组件零部件
Fig.8 PISTON & GP-ROD

图 8 活塞连杆组件零部件 Fig. 8 PISTON & GP-ROD

标号 Ref. No.	名称 NAME	件号 PART No.	数量 Quantity
			05AZ501
1	活塞/PISTON	05AL502	6
2	第一道气环/RING-PISTON TOP	1006694	6
3	第二道气环 RING-PISTON (INTERMEDIATE)	1006695	6
4	油环/RING- OIL	6I0499	6
5	活塞销/PIN	7N9805	6
6	锁簧/RETAINER	1S9543	12
*7	连杆机械加工部件/ROD ASSEMBLY	8N1721	6
(8)	连杆 (锻坯)/ROD	8N1720	6
(9)	连杆螺栓/BOLT	1P9956(1/2-20×74.4)	12
(10)	连杆螺母/NUT	5S6348(1/2-20)	12
(11)	连杆衬套/BEARING CONNECTING ROD	8N1849	6
12	连杆轴瓦/BEARING	4W5739	12

*7: 连杆机加工部件中包括标号为 (8) (9) (10) (11) 的零部件/*7: Rod AS. includes parts of Ref.No. (8)、(9)、(10)、(11).

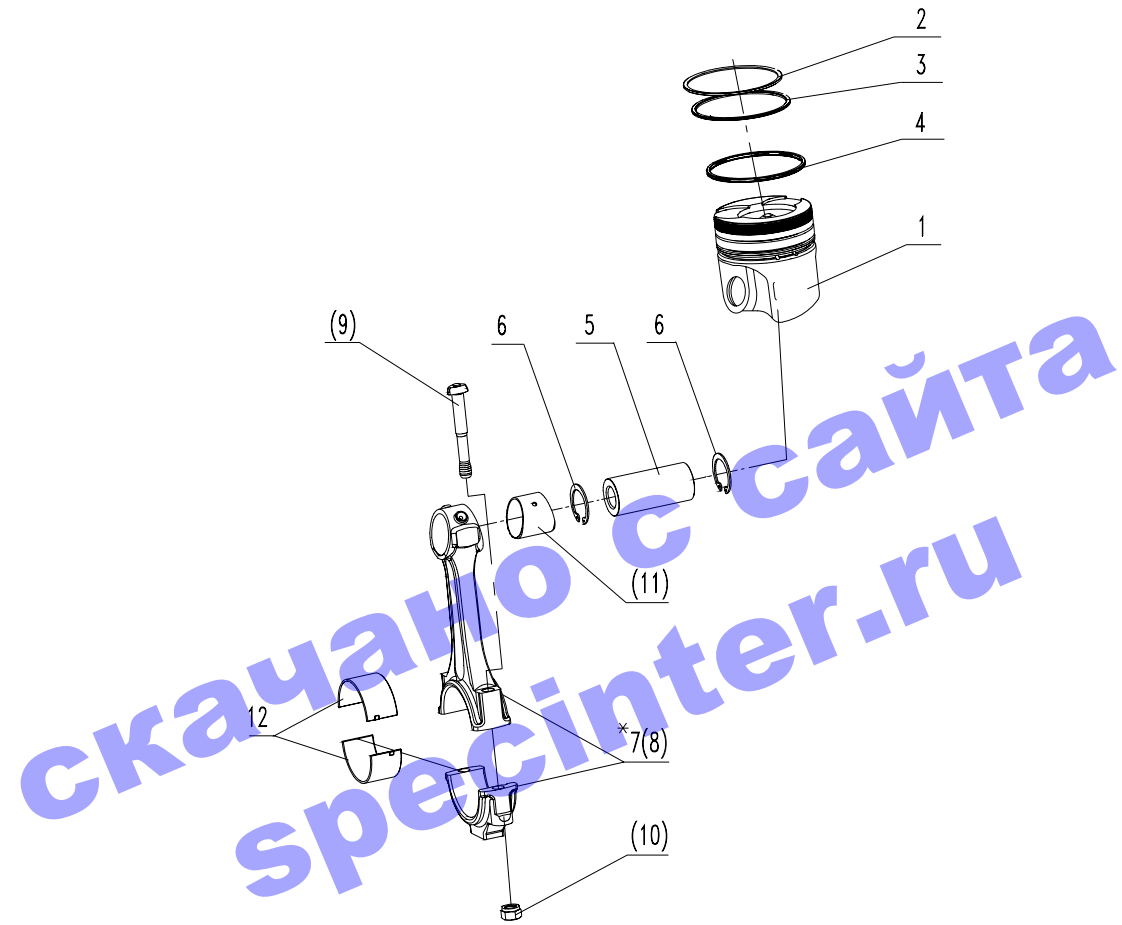

图9 曲轴组件零部件
FIG.9 CRANKSHAFT GP

图 9:曲轴组件零部件/Fig. 9: CRANKSHAFT GP

标号 Ref. No.	名称 NAME	件号 PART No.	数量 Quantity
			06AZ102
1	曲轴/CRANKSHAFT AS.	06AL102	1
2	主轴瓦/BEARING	4W5738	7
3	曲轴齿轮/GEAR (CRANKSHAFT)	1W4405	1
4	推力片/PLATE	1003652	2
5	半圆键 9#KEY-WOODRUFF#9 (SPECIAL)	5H2671	1
6	螺塞/PLUG	9F2247(1/8-27)	6

скачано с сайта
specinter.ru

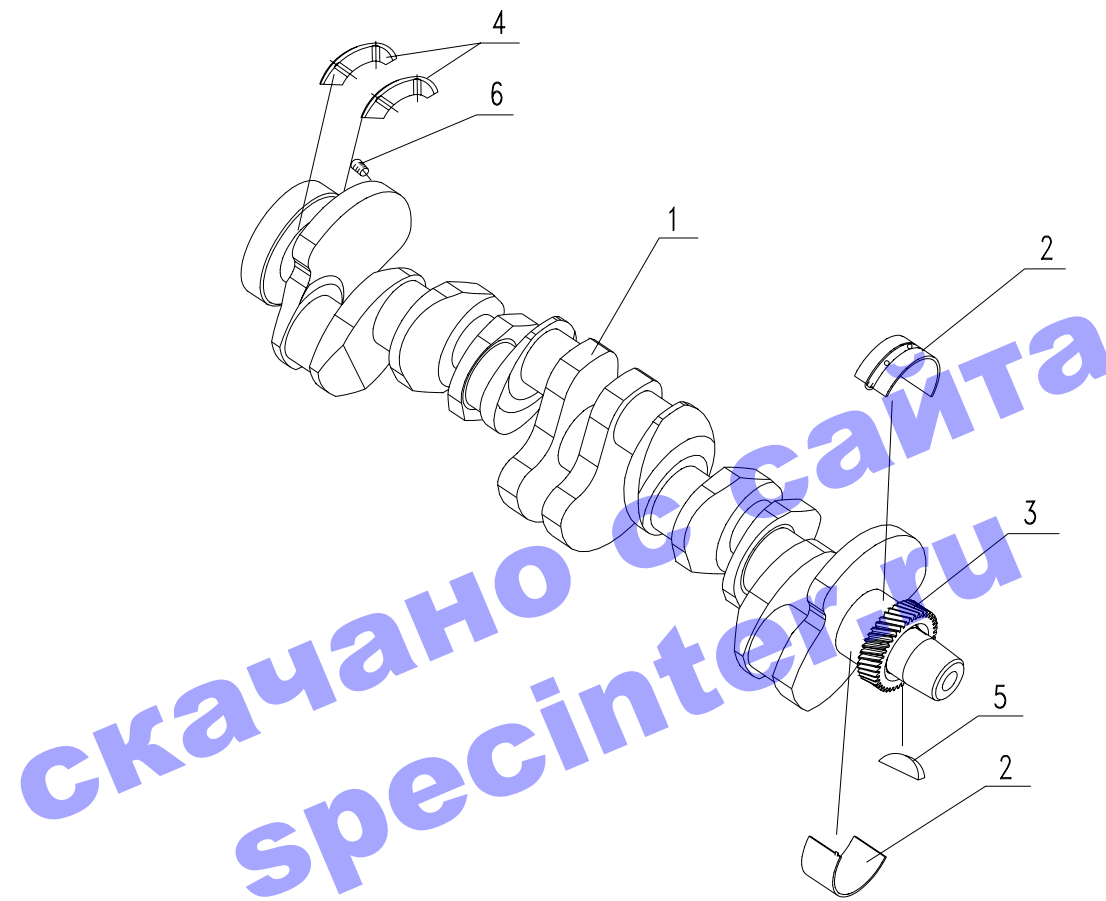
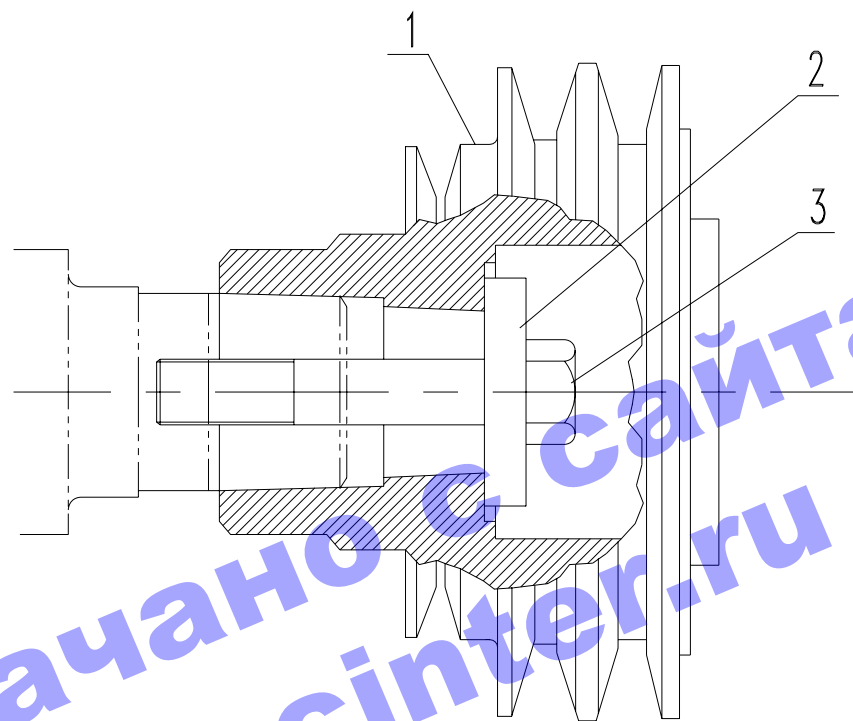

06BZ007

图10 曲轴皮带轮组件零部件

FIG.10 PULLEY GP-CRANKSHAFT

图 10 曲轴皮带轮组件零部件 FIG. 10 PULLEY GP-CRANKSHAFT

标号 Ref. No.	名称 NAME	件号 PART No.	数量 Quantity
			06BZ007
1	曲轴皮带轮/PULLEY	06BL008	1
2	皮带轮垫圈/WASHER	5S9948	1
3	六角头螺栓/BOLT	06BL004(3/4-16×120.65)	1

скачано с сайта
specinter.ru

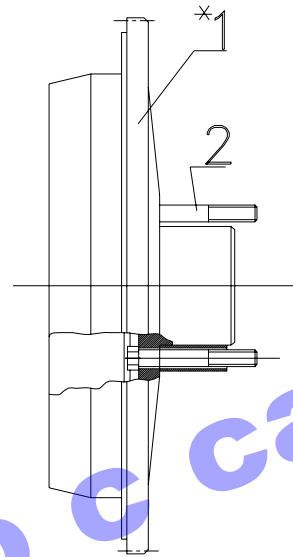

скачано с сайта
specinter.ru

06CZ002

图11 飞轮组件零部件

FIG.11 FLYWHEEL GP

图 11: 飞轮组件零部件/ Fig. 11: FLYWHEEL GP

标号 Ref No.	名 称 NAME	件号 PART No.	数量 Quantity
			06CZ002
*1	飞轮与齿圈装配加工部件 FLYWHEEL AS.	06CB002b	1
(2)	飞轮/FLYWHEEL	06CL002b	1
(3)	起动齿圈/GEAR-FLYWHEEL STARTER	06CL003(138 齿)	1
2	六角头螺栓/BOLT	0T0857(5/8-18×114.3)	9

*1: 飞轮与齿圈装配部件级加工部件中包括标号为 (2)、(3) 的零部件/*1: Flywheel AS. includes parts of Ref.No. (2)、(3)

скачано с сайта
specinter.ru

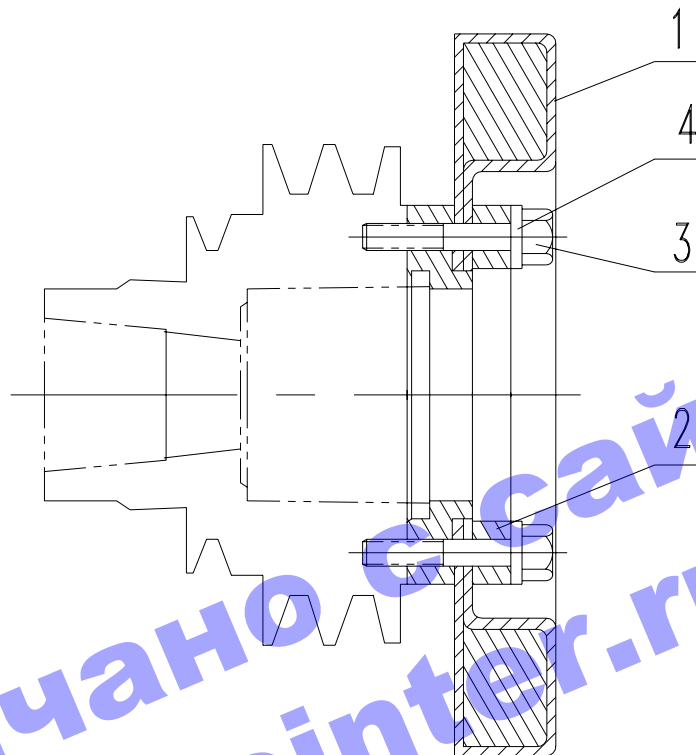

скачано с сайта
specinter.ru

9N2345

图12减震器组件零部件

FIG.12 DAMPER GP

图 12:减震器组件零部件/ Fig. 12: DAMPER GP

标号 Ref. No.	名称 NAME	件号 PART No.	数量 Quantity
			9N2345
1	减震器部件/DAMPER AS	1678123	1
2	接盘/ADAPTER-VISCOUS DAMPER	9L6261	1
3	六角头螺栓/BOLT	0S1587(1/2-13×44.45)	6
4	垫圈/WASHER	5P8245(13.5×25.5×3.0)	6

скачано с сайта
specinter.ru

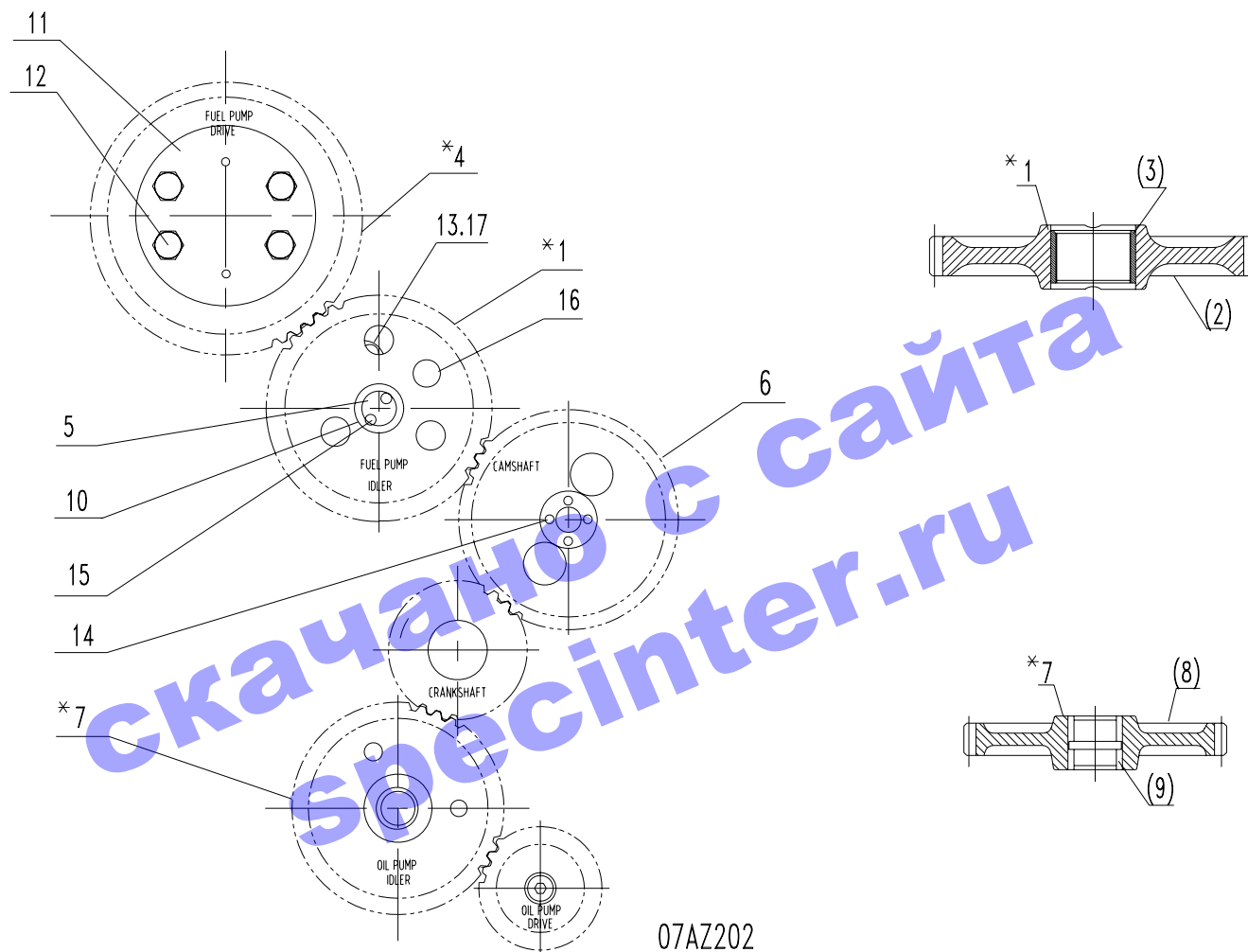

07AZ202

图13 定时齿轮组件零部件

FIG.13 GEAR GP-FRONT

图 13: 定时齿轮组件零部件/ Fig. 13: GEAR GP-FRONT

标号 Ref. No.	名称 NAME	件号 PART No.	数量 Quantity
			07AZ202
*1	喷油泵惰齿轮装配部件 GEAR AS. -FUEL PUMP IDLER	1064497	1
(2)	喷油泵惰齿轮/GEAR -FUEL PUMP IDLER	7W0546	1
(3)	喷油泵惰齿轮轴套/BEARING-SLEEVE	2S6692	1
*4	喷油泵传动齿轮 GEAR-FUEL PUMP DRIVE	07AL201b	1
5	喷油泵惰齿轮轴 SHAFT -ACCESSORY DRIVE IDLER	1059772	1
6	凸轮轴齿轮/GEAR-CAMSHAFT	1W4402	1
*7	机油泵惰齿轮装配部件 GEAR AS. -OIL PUMP IDLER	7N4722	1
(8)	机油泵惰齿轮/GEAR - OIL PUMP IDLER	7W0449	1
(9)	机油泵惰齿轮轴套/BEARING SLEEVE	2P1168	1
10	止推片/PLATE-THRUST	8N4960	1
11	齿轮压板/PLATE	07AL202b	1
12	六角头螺栓/BOLT	GB/T5783-M10×30-10.9-Y	4
13	六角头螺栓/BOLT	0S1594	2
14	六角头螺栓/BOLT	0S1748	4
15	六角头螺栓/BOLT	0S1618	2
16	六角头螺母/NUT	5B9079	1
17	平垫圈/WASHER-HARD	5M2894	2

*1:喷油泵惰齿轮装配部件中包括标号为(2)、(3)的零部件/*1: Gear-fuel Pump Idler includes parts of Ref.No.(2)、(3).

*7:机油泵惰齿轮装配部件中包括标号为(8)、(9)的零部件/*7: Gear AS.-Oil Pump Idler includes parts of Ref.No.(8)、(9).



图14 消声器组件零部件和防雨帽组件

FIG.14 MUFFLER GP AND RAIN CAP GP

图 14: 消声器组件零部件和防雨帽组件 FIG. 14 MUFFLER GP AND RAIN CAP GP

标号 Ref. No.	名 称 NAME	件号 PART No.	数量 Quantity	
			08AZ022	7S1784
1	消声器部件/MUFFLER AS.	7S8443	1	
2	夹箍/CLAMP	7H4266	1	
3	排气管/PIPE-EXTENSION EXHAUST	08AL047	1	
4	夹箍/CLAMP	6F8815	1	
5	I 型六角螺母/NUT-FULL	GB/T6170-M10	2	
6	六角头螺栓/BOLT	GB/T5783-M10×40	2	
7	平垫圈	GB/T97.1-10-200HV	4	
*8	排气管防雨帽组件 (小) CAP AS. -RAIN(EXHAUST)	7S1784		1

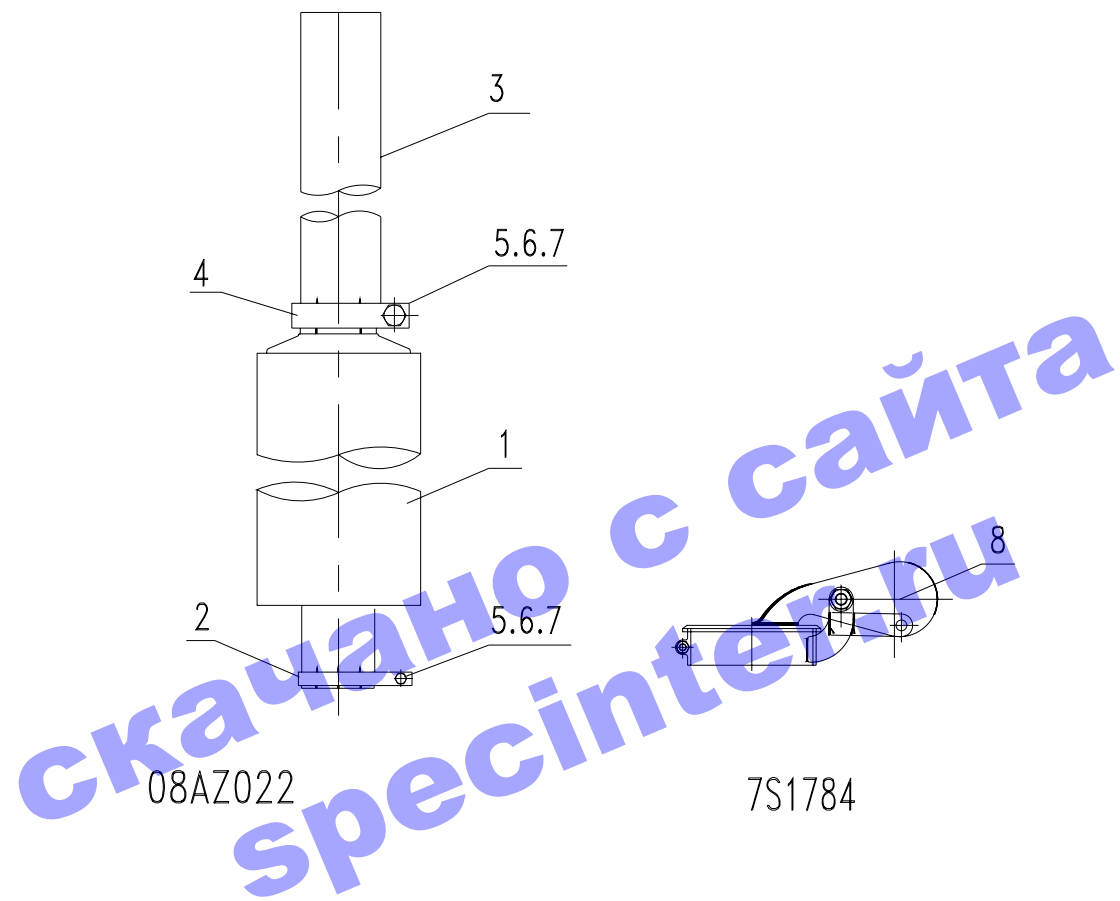
скачано с сайта
specinter.ru



图15 凸轮轴组件零部件
FIG.15 CAMSHAFT GP

图 15: 凸轮轴组件零部件/ Fig. 15: CAMSHAFT GP

标号 Ref. No.	名 称 NAME	件号 PART No.	数量 Quantity
			1N4406
1	凸轮轴/CAMSHAFT	7E9980	1
2	推力片 WASHER-THRUST (CAMSHAFT)	7S2204	1
3	止动垫片/LOCK	8S1491	1
4	六角头螺栓/BOLT	0S0509(3/8-16×19.05)	2

скачано с сайта
specinter.ru

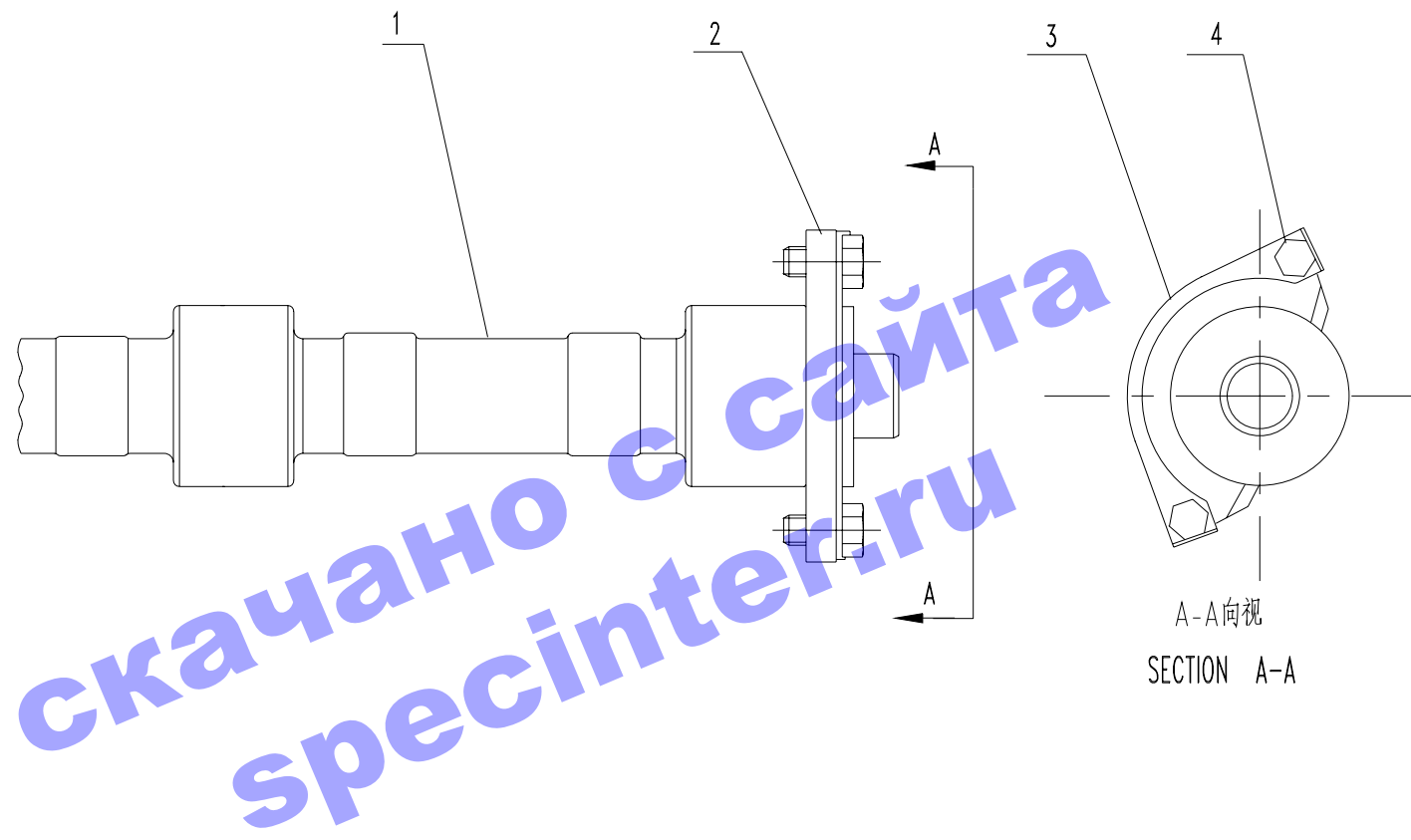
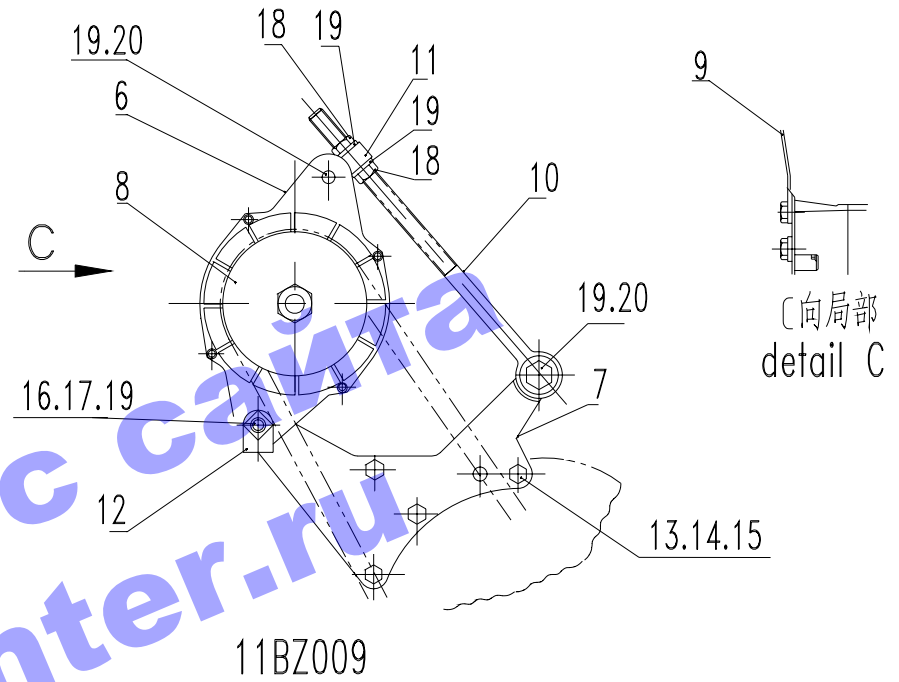
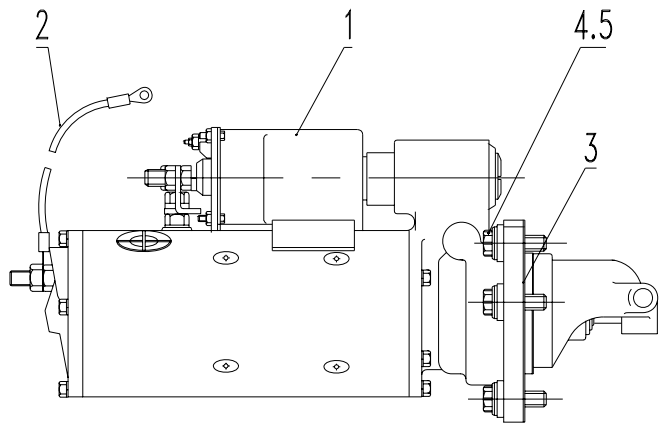

скачано с сайта
specinter.ru

图16 起动电机组件和充电发电电机组件零部件
FIG.16 MOTOR AND ALTERNATOR GP

图 16: 起动电机组件和充电发电电机组件零部件

Fig. 16: MOTOR AND ALTERNATOR GP

标号 Ref. No	名称 NAME	件号 PART No.	数量 Quantity	
			11AZ003	11BZ009
1	起动电机部件/MOTOR GP. ELECTRIC STARTING BASIC (24V)	4N3181(8C3651)	1	
2	电线部件/WIRE AS.	3N0539	1	
3	垫片/GASKET	4H7869	1	
4	小六角头螺栓/BOLT	Q/SC611.1-M16×40	3	
5	平垫圈/WASHER-HEAD	2S0736(17.0×27.0×3.5)	3	
6	充电发电机部件 ALTERNATOR GP. -CHARGING (BASIC) (24V-35A)	6N9294		1
7	发电机支架/BRACKET	2W9286		1
8	发电机皮带轮/PULLER	6N0714		1
9	电线部件/WIRE AS.	4N5092		1
10	发电机调节杆 ROD-ALTERNATOR ADJUSTING	9L6371		1
11	滑块/BLOCK	9L6329		1
12	螺母部件/NUT AS.	9S1240		1
13	六角头螺栓/BOLT	8T7008(3/8-16×76.2)		4
14	平垫圈/WASHER-HARD	8T4896(10.2×18.5×2.5)		4
15	六角螺母/NUT-FULL	1D4717(3/8-16)		4
16	平垫圈/WASHER	7X0574(13.5×27.0×3.0)		1
17	六角头螺栓/BOLT	7X0338(1/2-13×152.4)		1
18	六角螺母/NUT	1B4430(1/2-20)		2
19	平垫圈/WASHER-HARD	2M0849(13.5×25.5×5.0)		4
20	六角头螺栓/BOLT	0S1587(1/2-13×44.45)		1
21	六角头螺栓/BOLT	7B3235(1/2-13×34.92)		1



图17 进气管路组件零部件

FIG.17 INTAKE MANIFOLD GP

图 17:进气管路组件零部件/ Fig. 17 INTAKE MANIFOLD GP

标号 Ref. No.	名称 NAME	件号 PART No.	数量 Quantity
			12AZ009
1	高温用软接管/HOSE-AIR	9S9736	1
2	喉箍/CLAMP	Q/SC1302-78~101	2
3	气缸盖进气弯管/ELBOW	12AL030	1
4	高温用软接管/HOSE-AIR	4N9215	1
5	喉箍/CLAMP	Q/SC1302-60~83	2
6	进气弯管 ELBOW-AIR TRANSFER	12AL024	1
7	六角头螺栓/BOLT	0S1571(3/8-16×44.45)	4
8	六角锥管螺塞/PLUG-PIPE	5M6214	1
9	内六角螺塞/PLUG-PIPE	Q/SC584.2-M20×1.5	1
10	复合式密封硬垫圈/WASHER	Q/SC1294-20	1
11	垫片/GASKET	5S6735	1
12	六角锥管螺塞/PLUG-PIPE	5M6213	1

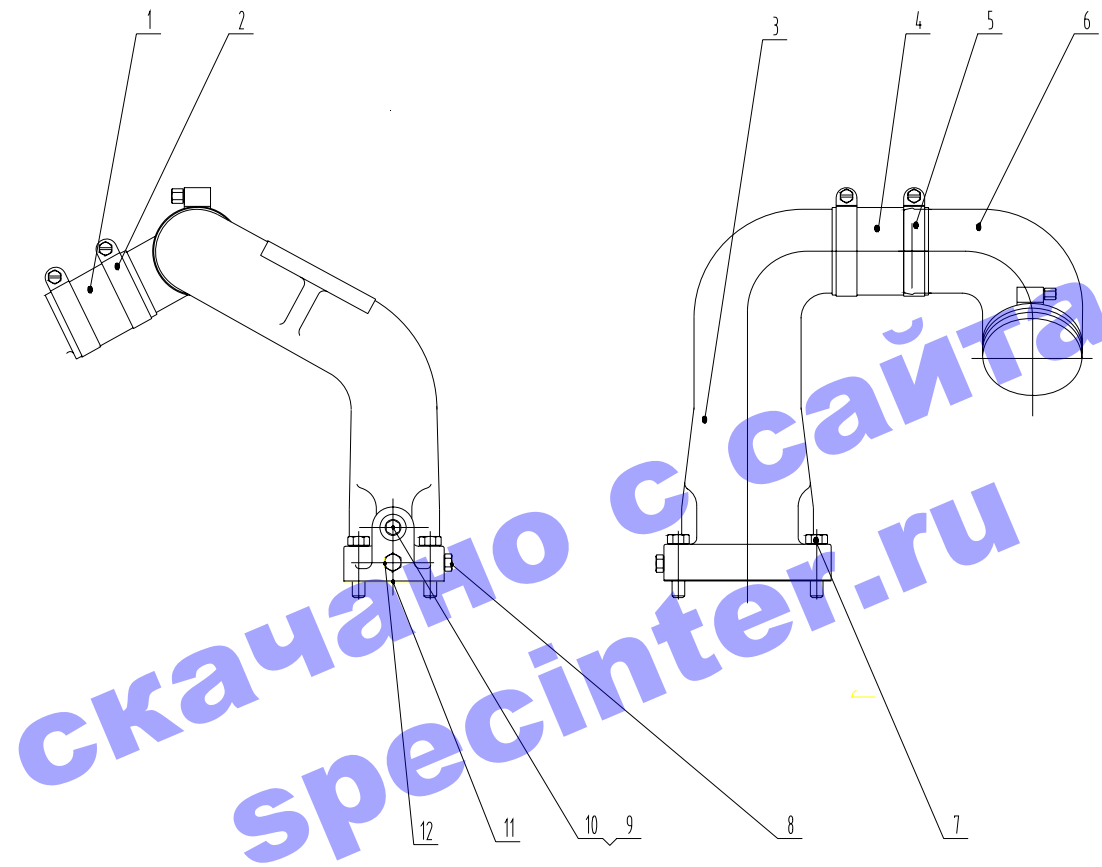
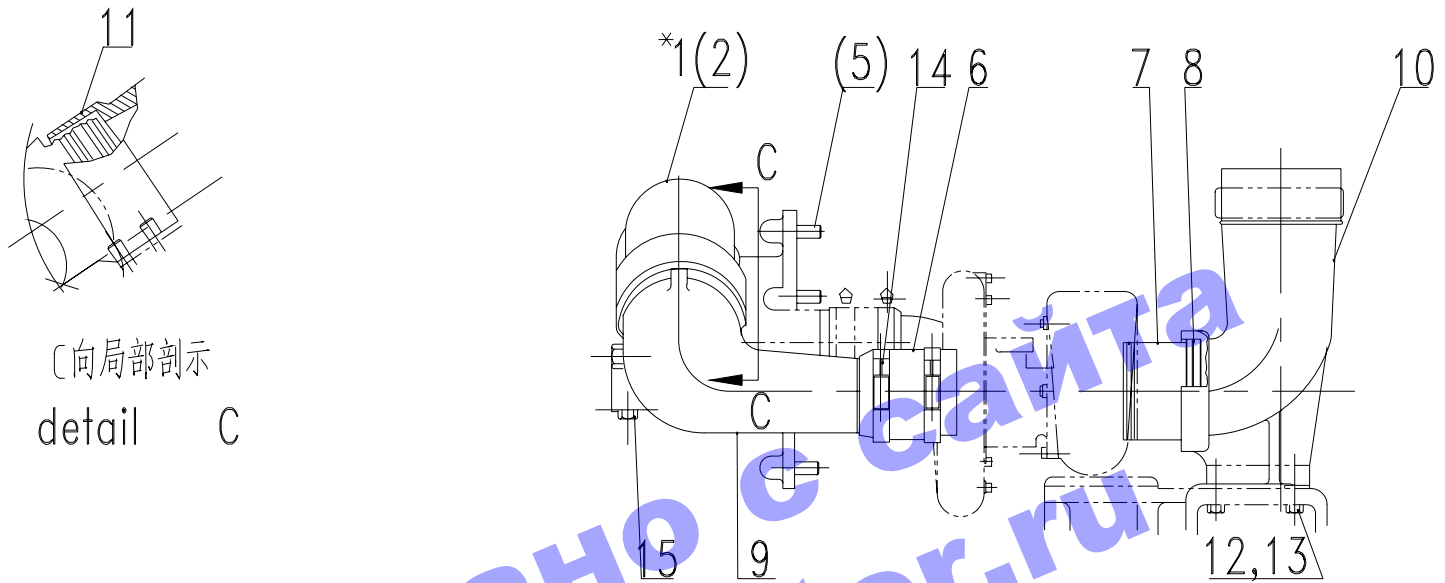

C向局部剖示
detail C

12BZ016

图18 进排气管路组件零部件

FIG.18 INTAKE AND EXHAUST MANIFOLD GP

图 18:进排气管路组件零部件/ Fig. 18: INTAKE AND EXHAUST MANIFOLD GP

标号 Ref. No.	名称 NAME	件号 PART No.	数量 Quantity
			12BZ016
1*	空滤器出口管部件/PIPE AS	4N8305	1
(2)	吸气管/PIPE-AIR TRANSFER	12BL053	1
(3)	六角锥管螺塞/PLUG-PIPE	5M6214	
(4)	小滤芯/ELEMENT-FILTER	7M1674	1
(5)	锥度锁紧双头螺塞/STUD	9M2151	8
6	软接管/HOSE	2S0387	1
7	涡轮出口接管 COUPLING-TURBOCHARGER EXHAUST	12BL052	1
8	金属密封环/SEAL RING-METAL	5L8855	2
9	压气机进口弯管 ELBOW-TURBO. COMPR. INLET	12BL047	1
10	涡轮排气接管 ELBOW-TURBO. COMPR. INLET	12BL046	1
11	O型密封圈/SEAL-O-RING	5H7704	2
12	六角头螺栓/BOLT	0S1571	4
13	六角螺母/NUT	1B5355	4
14	喉箍/HOOP	Q/SC1302-91~114	2
15	六角头螺栓/BOLT	1A2029(3/8-16×28.58)	3
(40)	螺纹接口/CONNECT	0A2926	1
(41)	空气滤清器保养指示器 INDICATOR-AIR FILTER	1W0613	1

1*:空滤器出口部件中包括标号为(2)、(3)、(4)、(5)、(40)、(41)的零部件./1*:PIPE AS. includes parts of Ref.No. (2)、(3)、(4)、(5)、(40)、(41) .

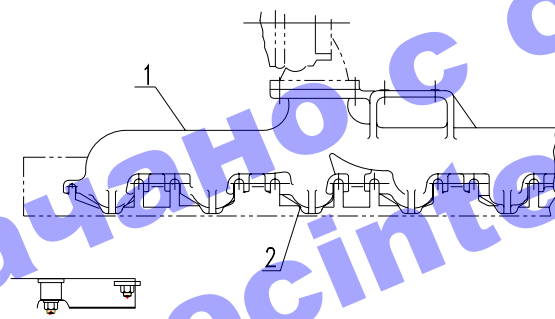
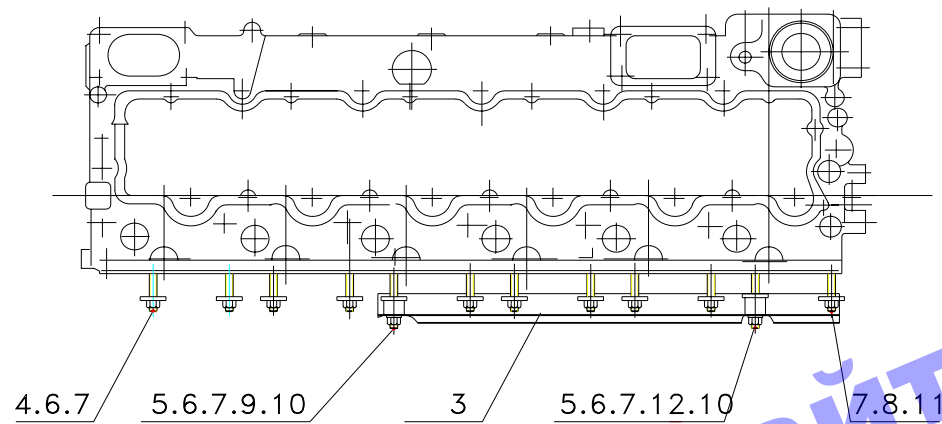

2P6573

8N1868

图19排气歧管组件和排气管紧固组件零部件

FIG.19.1 EXHAUST MANIFOLD AND FASTENER GP

图 19 排气歧管组件和排气管紧固组件零部件 Fig. 19: EXHAUST MANIFOLD AND FASTENER GP

标号 Ref. No	名称 NAME	件号 PART No.	数量 Quantity	
			2P6573	8N1868
1	排气歧管/MANIFOLD	9S2354	1	
2	排气管垫片/GASKET	9Y1979	3	
3	隔热板/SHIELD-HEAT	4P3306		1
4	高温锥形锁紧螺栓/STUD	6V1426		9
5	高温锥形锁紧螺栓/STUD	6V1427		2
6	平垫圈/WASHER	2S6160(10.2×32.0×5.0)		11
7	锁紧螺母/LOCKNUT	2N2766(3/8-16)		12
8	锥度锁紧双头螺栓/STUD	1061793		1
9	隔圈/SPACER	1M7643		1
10	平垫圈/WASHER	5M2894(10.2×18.5×2.5)		2
11	平垫圈/WASHER	9M6527		1
12	隔圈/SPACER	6B7469		1

скачан с сайта
specinter.ru

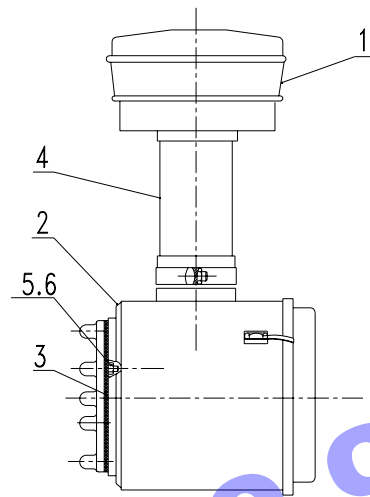

2P1484,14AZ007

скачано с сайта
specinter.ru

图20.1 空滤器组件零部件

FIG.20.1 CLEANER GP-AIR

图 20:空气滤清器组件、空滤器保养指示仪组件和灰尘引射管组件零部件

Fig. 20: AIR CLEANER、GAGE AND DUST EJECTOR GP

标号 Ref. No	名称 NAME	件号 PART No.	数量 Quantity
			14AZ007
1	粗滤器部件/PRE-CLEANER-AIR	14AB008	1
2	精滤器部件/CLEANER GP-AIR-B	6I2581	1
	(主滤芯部件)/ELEMENT AS-PRIM	6I0273	1
	(内滤芯部件)/ELEMENT AS-PRIM	6I0274	1
3	垫片/GASKET	1143540	1
4	接管部件/HOSE AS.	14AB009	1
5	平垫圈/WASHER	8T4896(10.2×18.5×2.5)	8
6	锁紧螺母/LOCK NUT	2K4973(3/8-16)	8

скачано с сайта
specinter.ru



图21 机油泵组件零部件(双齿轮)
 FIG.21 ENGINE OIL PUMP GP (TWO SECTION GEAR)

图 21: 机油泵组件零部件(双齿轮)/Fig. 21: ENGINE OIL PUMP GP (TWO SECTION GEAR)

标号 Ref.No.	名称 NAME	件号 PART No.	数量 Quantity
			2P1784
*1	机油泵部件 PUMP GP-ENGINE OIL (TWO SECTION GEAR)	6N2642	1
2	吸油管/ELBOW-SCAVENGE LINE	4N5353	1
3	垫片/GASKET	2P8746	1
4	六角头螺栓/BOLT	0S1590(3/8-16×50.8)	3
5	六角头螺栓/BOLT	0S1619(3/8-16×76.2)	1
6	六角头螺栓/BOLT	3B1915(3/8-16×34.92)	2
7	垫圈/WASHER-HARD	5M2894(10.2×18.5×2.5)	4
**8	机油泵试验部件/ENGINE OIL PUMP AS.	4W2448	1
**9	驱动齿轮/GEAR-OIL PUMP DRIVE	7W0507	1
**10	半圆键/KEY-WOODRUFF-10	8M5599	1
**11	六角头螺栓/BOLT	0S1590(3/8-16×50.8)	1
**12	垫圈/WASHER-HARD	1P7346(10.2×35.0×6.0)	1
***13	吸油泵体部件 BODY ASSEMBLY-SCAVENGE PUMP	4W2321	1
***14	泵体部件/BODY AS. -OIL PUMP	4W2322	1
***15	主动轴部件/DRIVE SHAFT AS.	2P6245	1
***16	从动轴部件/SHAFT ASSEMBLY-OIL PUMP	8S0493	1
***17	吸油泵齿轮 GEAR-OIL PUMP (GEAR-SCAVENGE PUMP)	6N1036(2P2546)	2
***18	机油泵隔板/SPACER-OIL PUM	2P1781	1

*1:6N2642 机油组件中包括标号为**8、**9、**10、**11、**12.的零部件

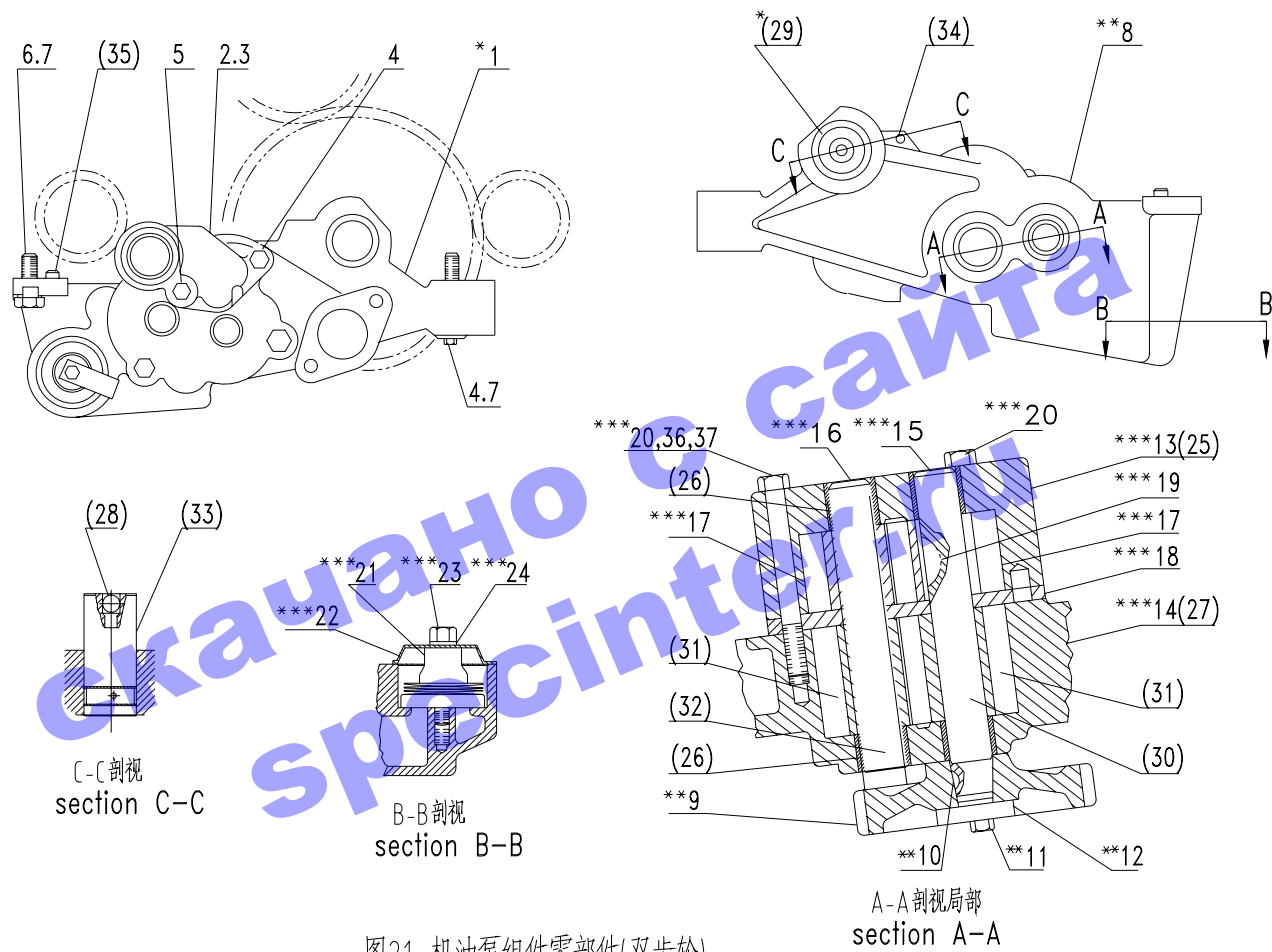
*1: Pump GP.-Engine Oil (Two Section Gear) 6N2642 includes parts of Ref.No.**8、**9、**10、**11、**12.

8:机油泵试验部件中包括标号为*13、***14、***15、***16、***17、***18、***19、***20、***21、***22、***23、***24 的零部件

8: Pump GP.-Engine Oil includes parts of Ref.No. *13、***14、***15、***16、***17、***18、***19、***20、***21、***22、***23、***24.

13:机油泵体部件中包括标号为(25)、(26)的零部件/13: Body AS.-Scavenge Pump includes parts of Ref.No.(25)、(26);

14:机油泵体部件中包括标号为.(26)、(27)、*(29)、(34)、(35)的零部件/14: Body AS.-Oil Pump includes parts of Ref.No.(26)、(27)、*(29)、(34)、(35);

15:主动轴部件中包括为(30)、(31)的零部件/15: Drive SHAFT includes parts of Ref.No.(30)、(31);

图 21: 机油泵组件零部件(双齿轮)/Fig. 21: ENGINE OIL PUMP GP (TWO SECTION GEAR)

16:从动轴部件中包括标号.(31)、(32)的零部件/16: Driven SHAFT includes parts of Ref.No.(31)、(32).

标号 Ref. No.	名称 NAME	件号 PART No.	数量 Quantity
			2P1784
***19	半圆键/KEY-WOODRUFF-10	1B8709	1
***20	六角头螺栓/BOLT	GB/T5782-M10×90	3
***21	卸压阀部件 PRESSURE RELIEF VALVE AS.	4N8385	1
***22	卸压阀盖 COVER-OIL PUMP BYPASS VALVE	4N3732	1
***23	六角头螺栓/BOLT	GB/T5782-M8×50	1
***24	垫圈/WASHER-HARD	GB/T97.1-8-200HV	1
(25)	吸油泵体/BODY-SCAVENGE PUMP	4N4054	1
(26)	轴套/BEARING-SLEEVE	8S6511	4
(27)	泵体/BODY-OIL PUMP	8N8635	1
(28)	钢球/STEEL BALL	GB/T308-10	1
*(29)	惰齿轮轴部件 SHAFT ASSEMBLY-OIL PUMP IDLER GEAR	2P1170	1
(30)	主动轴/DRIVE SHAFT	2P0691	1
(31)	机油泵齿轮/GEAR-OIL PUMP	2P2545	2
(32)	从动轴/SHAFT-OIL PUMP	8S0490	1
(33)	惰齿轮轴/SHAFT-OIL PUMP IDLER GEAR	2P1169	1
(34)	钢球/STEEL BALL	GB/T308-8	1
(35)	圆柱销/DOWEL	1F1006(9.368×15.75)	1
36	垫圈/WASHER	GB/T97.1-10-200HV	3
37	弹簧垫圈/SPRING WASHER	GB/T93-10	3
38	碟形弹簧/SPRING-CONED DISC	4N8384	5
39	卸压阀座/PEDESTAL	8N8118	1
40	定位圈/RETAINER	2P7717	1
41	定位套/SHEATH	15AL001	2

* (29) 惰齿轮轴部件中包括标号为(28)、(33)的零部件/*(29): SHAFT AS.-Oil Pump Idler Gear includes parts of Ref.No.(28)、(33).

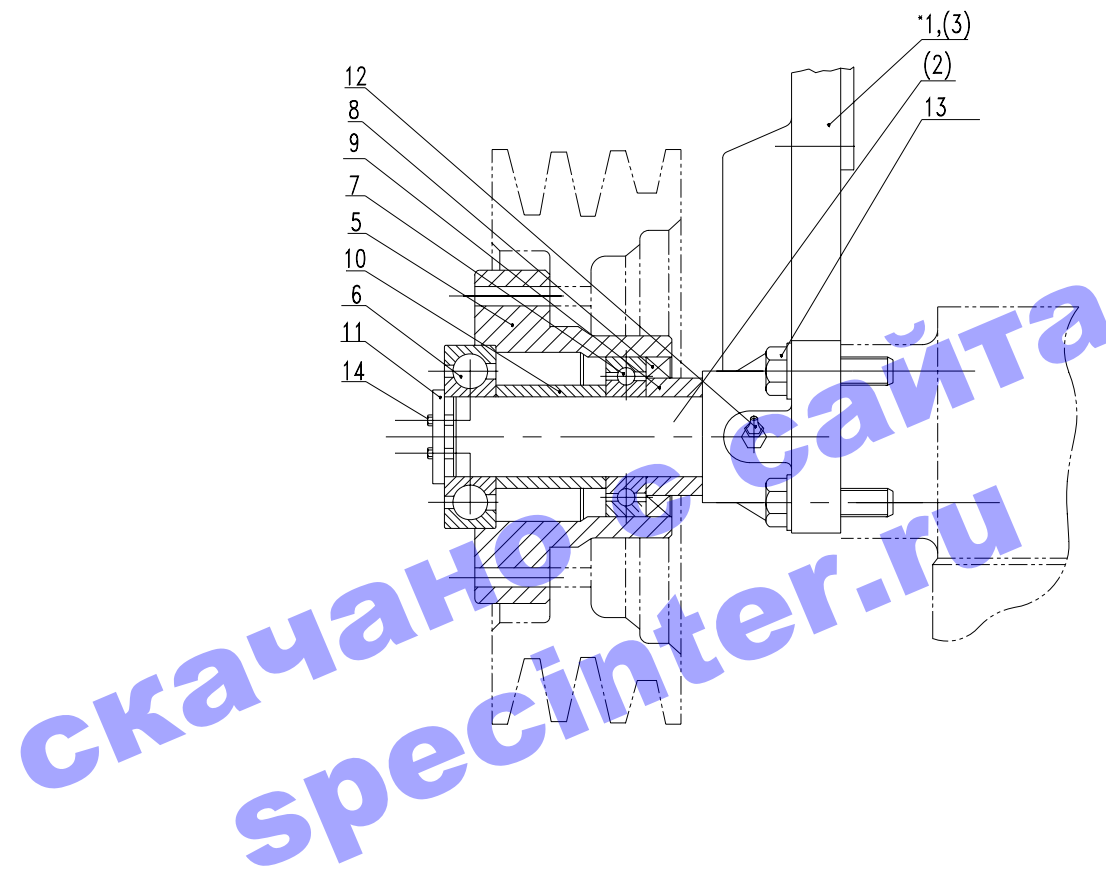

16AZ009

图22 风扇支架组件零部件

FIG.22.1 FAN DRIVE GP

图 22: 风扇支架组件零部件/ Fig. 22: FAN DRIVE GP

标号 Ref. No.	名称 NAME	件号 PART No.	数量 Quantity
			16AZ009
*1	风扇支架加工部件 FAN SHAFT BRACKET AS.	16AB008	1
(2)	风扇轴/SHAFT-FAN	1P9946	1
(3)	风扇轴支架/BRACKER-FAN	1P9899	1
(4)	圆柱销/CYLINDRICAL PIN	GB/T119-B10×18	1
5	风扇法兰/HUB-FAN PULLEY	2P1757	1
6	深沟球轴承/BALL BEARING	GB/T276-6307	1
7	深沟球轴承/BALL BEARING	GB/T276-6207	1
8	骨架式橡胶油封 RUBBER OIL SEAL	HG4-692-SG50×72×12	1
9	隔圈/SPACER	16AL002	1
10	隔圈/SPACER	8N5305	1
11	压紧垫圈/WASHER-RETAINING	5S7264	1
12	直通式压注油环/OIL WREATH	GB/T1152-M10×1	1
13	六角头螺栓/BOLT	5P2566(1/2-13×38.1)	4
14	六角头螺栓/BOLT-SELF LOCKING	6V4626(5/16-24×50.8)	2

*1:16AB003 风扇轴支架加工部件中包括标号为.(2)、(3)、(4)的零部件

*1: BRACKET-Fan SHAFT 16AB003 includes parts of Ref.No.(2)、(3)、(4).

注*2W4546 为调节垫块部件, 7C5632 为调节垫块零件号/Note*2W4546 includes parts of 7C5632.



图23 风扇皮带轮组件, 三角带组件和风扇联轴节组件零部件
FIG.23 FAN PULLEY, VEE BELT SET AND FAN ADAPTER GP

图

23: 风扇皮带轮组件、三角带组件和风扇联轴节组件零部件
 Fig. 23: FAN PULLEY、VEE BELT SET AND FAN ADAPTER GP

标号 Ref.No.	名称 NAME	件号 PART No.	数量 Quantity	
			16BZ015	16CZ008
1	风扇皮带轮部件 FAN PULLEY AS.	16BB026	1	
	风扇皮带轮/FAN PULLEY	16BL045	2	
	风扇皮带轮/FAN PULLEY	16BL047	1	
2	风扇联轴节部件 FAN ADAPTER AS.	16BB013	1	
(3)	风扇联轴节/FAN ADAPTER	16BL027	1	
(4)	闷头/PLUG	16BL020(同 761G-04-052)	1	
5	O 型密封圈/SEAL-O-RING	9F4446(78.74×5.33)	1	
6	六角头螺栓/BOLT	0T0573(3/8-16×69.85)	6	
7	平垫圈/WASHER-HARD	8T4896(10.2×18.5×2.5)	6	
8	三角皮带部件/V-BELT AS.	2W8951		1
(9)	三角皮带/V-BELT	1M7303		2

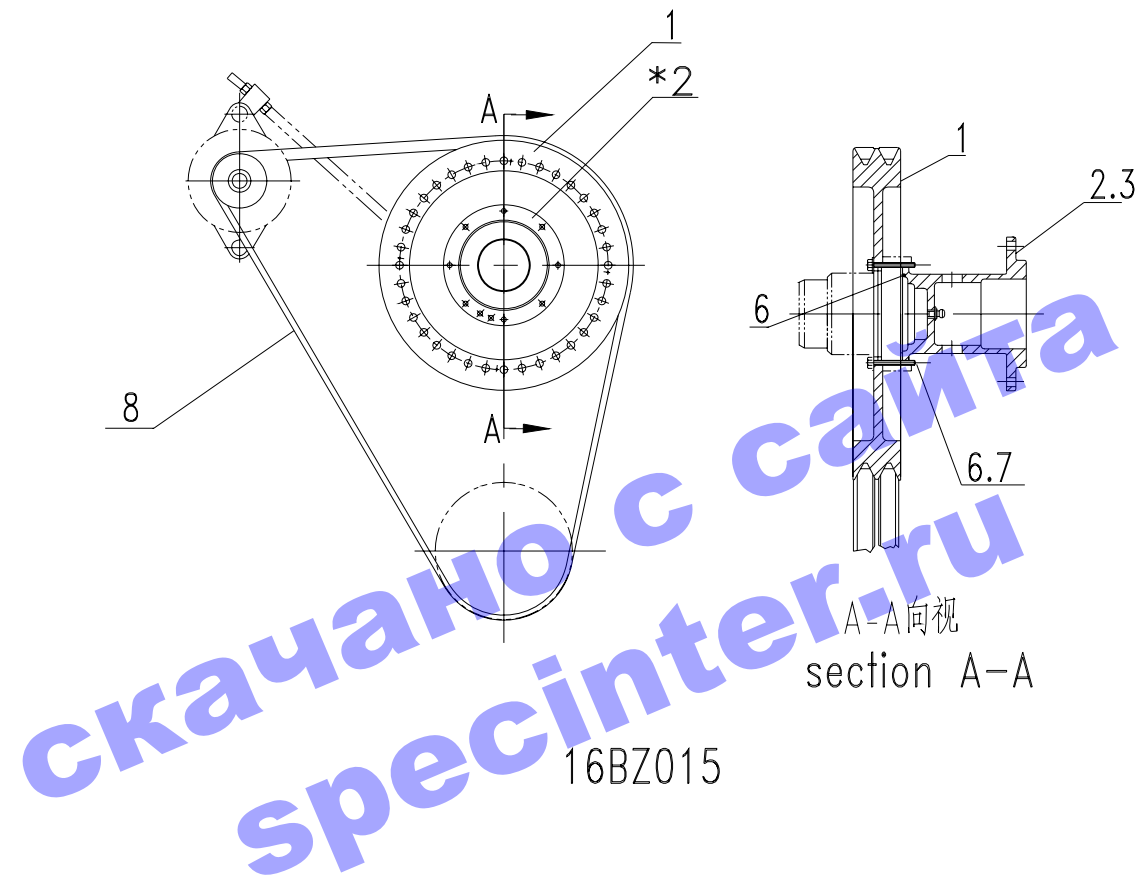

图24 风扇及防护罩组件和吹风式风扇组件零部件

FIG.24 FAN & GUARD GP

图 24: 风扇及防护罩组件和吹风式风扇组件零部件 Fig. 24: FAN & GUARD GP

标号 Ref. No	名 称 NAME	件号 PART No.	数量 Quantity
			16DZ009
1	风扇铆接部件(吹风式) SPIDER AS. -FAN (BLOWER)	1N3586	1
	风扇叶焊接部件 SPIDER AS. -FAN	16DB001	1
8	六角头螺栓/BOLT	5S7382(3/8-16×34.92)	6
9	硬垫圈/WASHER-HARD	8T4896(10.2×18.5×2.5)	6
18	风扇托板与垫板焊接部件/WELD AS.	16DB002	1
20	风扇后托板/PLATE	16DL004	1
	铆钉/RIVET	GB/T867-6×26	36

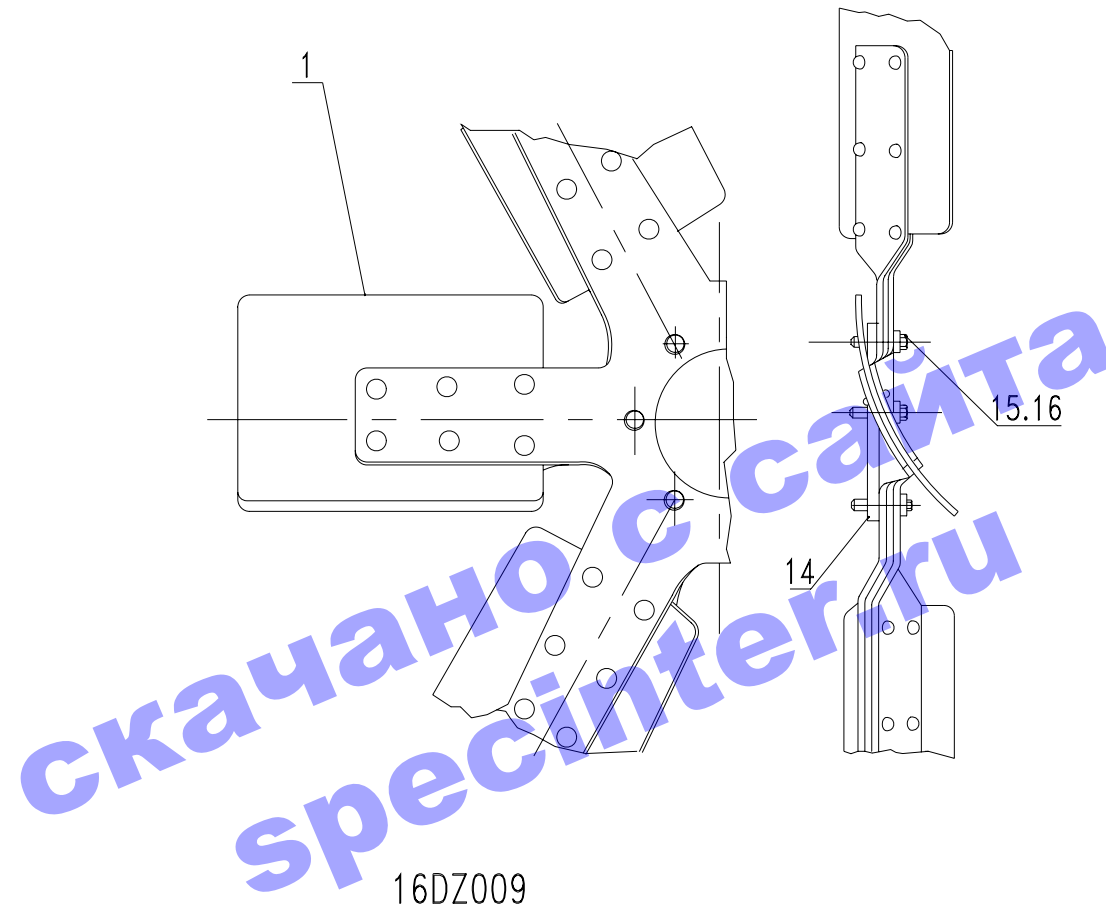
скачано с сайта
specinter.ru

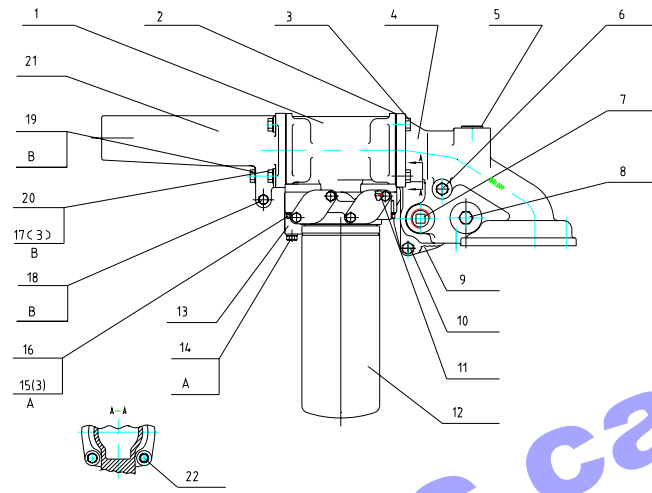

скачано с сайта
specinter.ru



图25 机油冷却器和滤清器组件零部件
FIG.25 COOLER & FILTER GP-OIL

图 25 机油冷却器和滤清器组件零部件 Fig25:COOLER & FILTER GP-OIL

标号 Ref. No.	名称 NAME	件号 PART No.	数量 Quantity
			18AZ009
*1	机油冷却器芯子机加工部件 CORE AS.-OIL COOLER	7N0165	1
2	垫片/GASKET	5S6051	2
3	六角头螺栓/BOLT	1A2029(3/8-16×28.58)	3
4	油冷器盖/COVER	18AL009	1
5	内方头锥管螺塞 PLUG-PIPE (SQUARE COUNTERSUNK)	3B0551	1
6	六角头螺栓/BOLT	5F4899(3/8-16×139.7)	1
7	内方头锥管螺塞 PLUG-PIPE (SQUARE COUNTERSUNK)	1B5174(3/4-14)	1
8	六角锥管螺塞/PLUG-PIPE	3J5390(3/8-18×14.2)	1
9	垫片/GASKET	2W4561	1
10	六角头螺栓/BOLT	0S1591(3/8-16×38.10)	1
11	O型密封圈/SEAL-O RING	8M4432(26.57×3.53)	2
12	机油滤清器部件/FILTER AS-OIL	2P4004(1R0658\1R0739)	1
*13	机油滤清器座装配部件 BASE GP-FILTER (OIL)	8N4457	1
14	六角头螺栓/BOLT	1D4540(5/16-18×69.85)	1
15	硬垫片/WASHER-HARD	9M1974(8.8×16×2.0)	4
16	六角头螺栓/BOLT	1B9575(5/16-18×44.45)	3
17	硬垫片/WASHER-HARD	5M2894 (10.2×18.5×2.5)	5
18	六角头螺栓/BOLT	3B1915(3/8-16×34.92)	1
19	六角头螺栓/BOLT	0L2070(3/8-16×57.15)	1
20	六角头螺栓/BOLT	0S1588(3/8-16×31.75)	3
21	水泵出水管/PIPE-PUMP OUTLET	2W5240	1
22	十二角头螺栓/BOLT-12 POINT HEAD	1T0765(3/8-16×25.40)	1

*1:7N0165 机油冷却器芯子焊接机加工部件中包括标号为.(23)、(24)的零部件*1: Core AS.-Oil Cooler 7N0165 includes parts of Ref.No.(23)、(24);

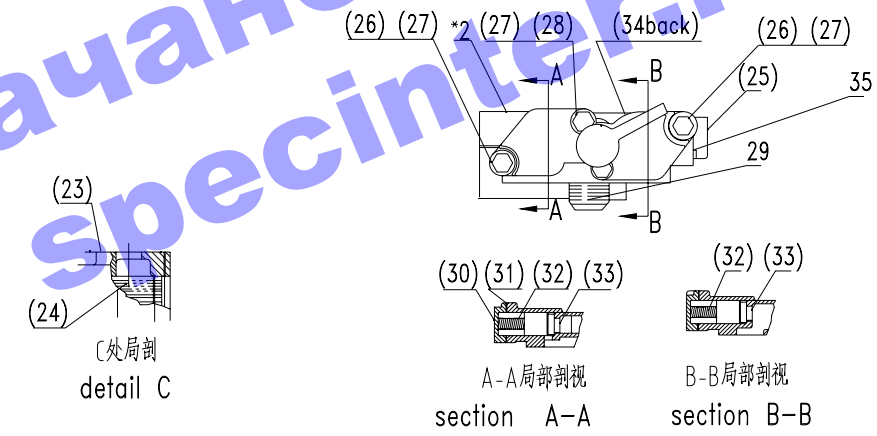
*13:8N4457 机油滤清器座装配部件中包括标号为(25)···(35)的零部件/*13: BAsE GP.-Filter (Oil) 8N4457 includes parts of Ref.No.(25)···(35).

图 25 机油冷却器和滤清器组件零部件 Fig25:COOLER & FILTER GP-OIL

标号 Ref. No.	名 称 NAME	件号 PART No.	数量 Quantity
			18AZ009
(23)	壳体/SHELL-CORE	7S6394	1
(24)	管束部件/BUNDLE AS. -TUBE	18AB005	1
(25)	滤清器座部件/Base AS. -OIL FILTER	9Y7149	1
(26)	六角头螺栓/BOLT	0S1618(5/16-18×25.4)	2
(27)	平垫圈/WASHER-HARD	9M1974(8.8×16×2.0)	4
(28)	六角头螺栓/BOLT	1B2790(5/16-18×34.92)	2
(29)	螺套内接头/CONNECTOR	2P2537	1
(30)	盖/COVER	9Y6859	1
(31)	垫片/GASKET	9Y6860	1
(32)	弹簧/SPRING	8M3182	2
(33)	阀体 PLUNGER-OIL COOLER RELIEF VALVE	9M0853	2
(34)	内方头锥管螺塞 PLUG-PIPE (SQUARE COUNTERSUNK)	3B0551	3
(35)	内方头锥管螺塞 PLUG-PIPE (SQUARE COUNTERSUNK)	2B0858	1

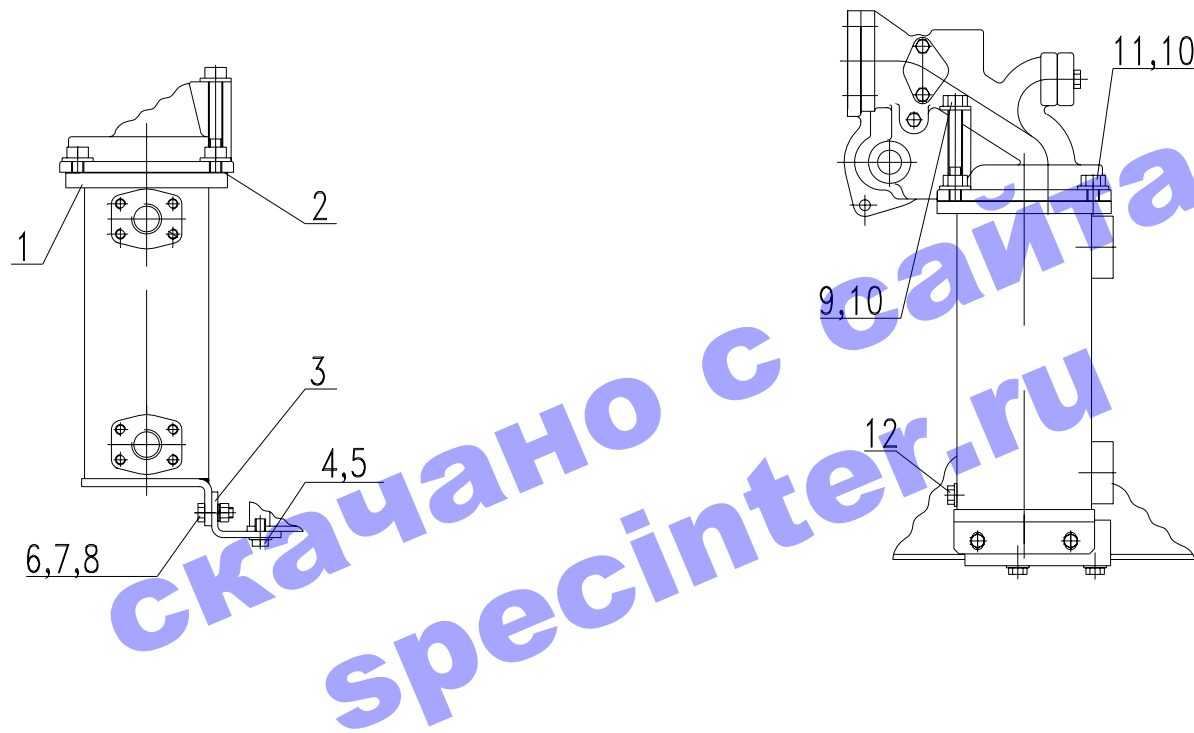
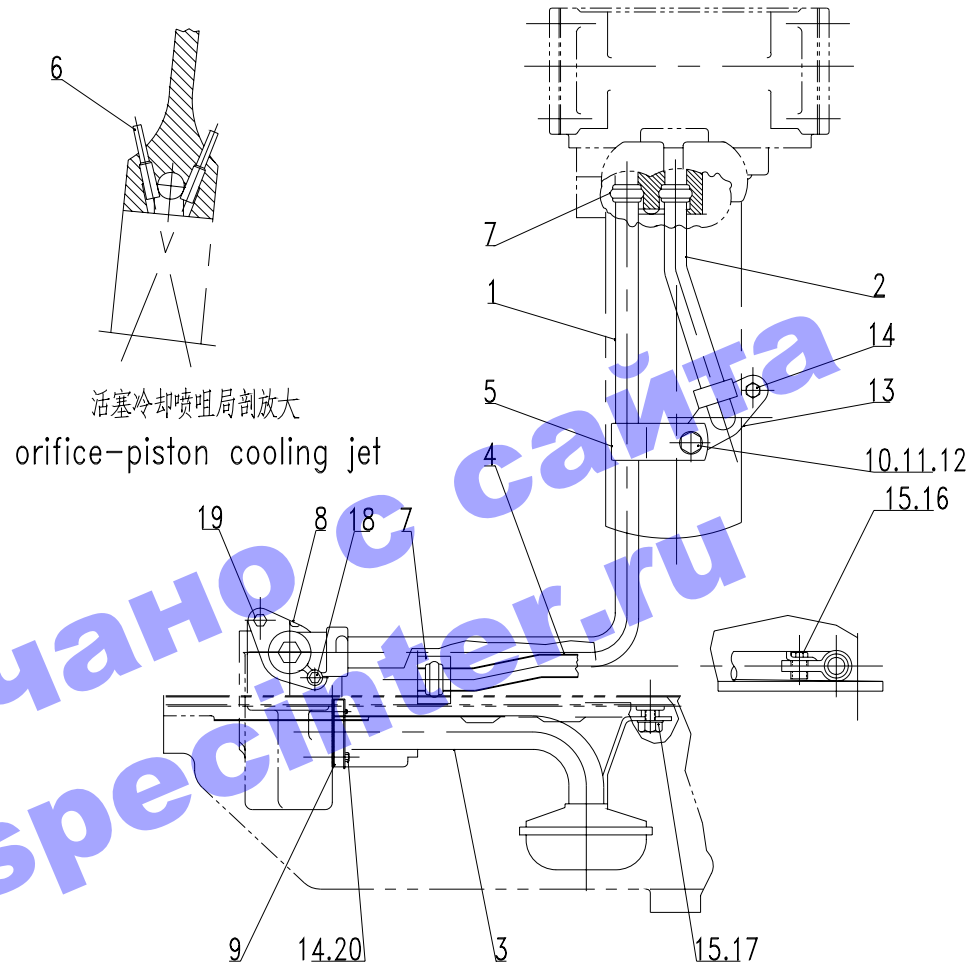

FIG.26 TRANSMISSION OIL COOLER GP

图26 传动装置油冷却器组件零部件

图 26: 传动装置油冷却器组件零部件/ Fig. 26: TRANSMISSION OIL COOLER GP

标号 Ref.	名称 NAME	件号 PART No.	数量 Quantity
			18BZ007
1	芯子焊接机加工部件/CORE AS.	18BB009	1
2	垫片/GASKET	18BL007a	1
3	托架/BRACKET	18BL008	1
4	六角头螺栓/BOLT	1A2029(3/8-16×28.58)	2
5	平垫圈/WASHER	5M2894(10.2×18.5×2.5)	2
6	六角头螺栓/BOLT	GB/T5783-M10×30	2
7	螺母/NUT	GB/T6170-M10	2
8	平垫圈/WASHER	GB/T93-10	2
9	六角头螺栓/BOLT	GB/T5782-M12×110	1
10	平垫圈/WASHER	GB/T 93-12	4
11	六角头螺栓/BOLT	GB/T5783-M12×30	3
12	放水阀/PLUG	761G-02-105	1



2P6105

图27 机油管路组件

FIG.27 LINES GP-ENGINE OIL

图 27: 机油管路组件零部件/ Fig. 27: LINES GP-ENGINE OIL

标号 Ref. No.	名称 NAME	件号 PART No.	数量 Quantity
			2P6105
1	机油滤清器机油管焊接部件/TUBE AS.	8N7318	1
2	机油滤清器机油管焊接部件/TUBE AS.	8N7315	1
3	机油泵吸油网焊接部件/BELL AS.	7W9020	1
4	机油泵油管加工部件/TUBE AS.	2P1739	1
5	夹头/CLIP	4L3641	1
6	活塞冷却喷嘴/ORIFICE	2S1541	6
7	O 型密封圈/SEAL	1142687(23.16×5.33)	3
8	垫片/GASKET	2M5407	1
9	垫片/GASKET	8M0904	1
10	隔圈/SPACER	1L5081	1
11	六角头螺栓/BOLT	0S1571	1
12	硬垫圈/WASHER	5M2894(10.2×18.5×2.5)	1
13	垫片/GASKET	7F7590	1
14	六角头螺栓/BOLT	0S1594(3/8-16×25.4)	3
15	六角头螺栓/BOLT	0T0102(3/8-16×15.88)	2
16	单耳止动垫片/LOCK	0L0364	1
17	单耳止动垫片/LOCK	5H3204	1
18	六角头螺栓/BOLT	0L2070(3/8-16×57.15)	1
19	六角头螺栓/BOLT	1A2029(3/8-16×28.58)	1
20	止动垫片/LOCK-NUT	8S8874	1



图28.增压器机油管路组件零部件

FIG.28 LINES GP-TURBOCHARGER OIL

图 28:增压器机油管路组件零部件/ Fig. 28: LINES GP-TURBOCHARGER OIL

标号 Ref. No.	名 称 NAME	件号 PART No.	数量 Quantity
			19BZ202
1	铰接螺栓/BOLT	Q/SC642.3-01-M16×1.5	1
2	复合垫片/WASHER	Q/SC1294-16	2
3	增压器进油管扩口部件/TUBE AS.	19BB027	1
4	回油管垫片/GASKET	1P1255	1
5	六角头螺栓/BOLT	GB/T5783-M10×30	2
6	平垫圈/WASHER	GB/T97.1-10-300HV-Y	2
7	六角头螺栓/BOLT	0S1617(5/16-18×19.05)	1
8	六角螺母/NUT	1D4716(5/16-18)	1
9	平垫圈/WASHER	9M1974(8.8×16×20)	2
10	夹头/CLIP	6N6033	2
11	增压器回油管焊接部件/TUBE AS.	19BB015	1
12	喷油泵支架/SUPPORT	19BL202	1
13	喷油泵支架/SUPPORT	19BL201b	1
14	六角头螺栓/BOLT	0T0055	1
15	平垫圈/WASHER	5M2894(10.2×18.5×2.5)	3
16	六角头螺栓/BOLT	1A2029(3/8-16×28.58)	3
17	O型橡胶密封圈/SEAL-O-RING	8M5248(28.17×3.53)	2
18	垫片/GASKET	4M6480	1
19	弯管接头/ELBOW	8N1149	1
20	六角头螺栓/BOLT	0L2070(3/8-16×57.15)	1
21	O型橡胶密封圈/SEAL-O-RING	9M4849(23.16×5.33)	1
22	铰接螺栓/BOLT	Q/SC642.1-01-M10×1	1
23	复合垫圈/WASHER	Q/SC1294-10	2
24	机油过渡接头/CONNECTOR	19BL205	1

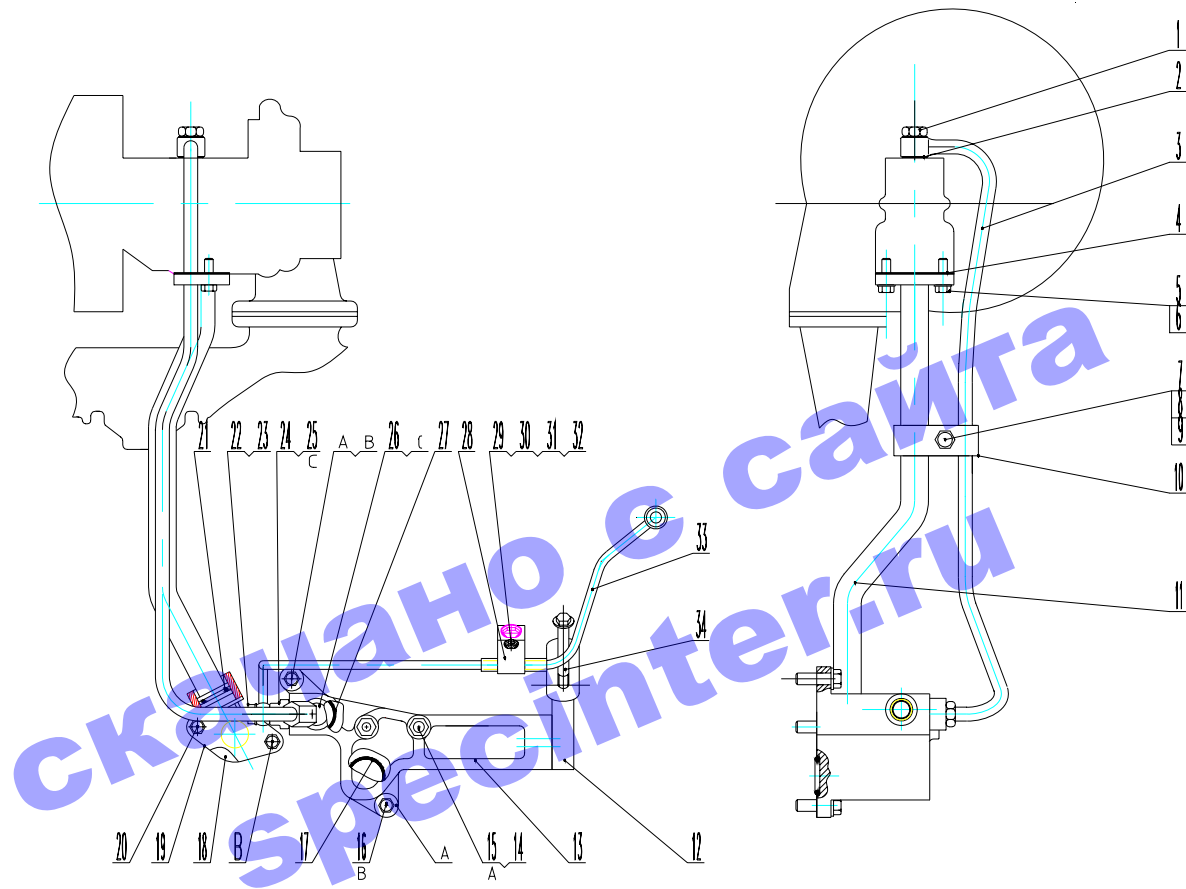
图 28:增压器机油管路组件零部件/ Fig. 28: LINES GP-TURBOCHARGER OIL

标号 Ref. No.	名 称 NAME	件号 PART No.	数量 Quantity
			19BZ202
25	0 型橡胶密封圈/SEAL-O-RING	3K0360(16.36×2.21)	2
26	直接头	8M0505	1
27	0 型橡胶密封圈/SEAL-O-RING	8M5253(18.72×2.62)	1
28	机油管夹头/CLIP	19BL206	1
29	六角头螺栓/BOLT	GB/T5783-M5×16	1
30	螺母/NUT	GB/T6170-M5	1
31	弹簧垫圈/LOCKWASHER	GB/T93-5	1
32	平垫圈/WASHER	Q/SC596-5×12	1
33	喷油泵机油进油管部件/TUBE AS.	19BB204	1
34	六角法兰面螺栓/BOLT	Q/SC622-M10x80-10.9	2



图29 水泵组件零部件
 FIG.29 PUMP GP-WATER

图 29:水泵组件零部件/ Fig. 29 PUMP GP-WATER

标号 Ref. No.	名称 NAME	件号 PART No.	数量 Quantity
			7N5909
*1	水泵部件/PUMP AS.	2W8001	1
2	O型密封圈/SEAL	5F3106(126.59×3.53)	1
3	六角头螺栓/BOLT	0T0055(3/8-16×107.95)	2
4	平垫圈/WASHER	5M2894(10.2×18.5×2.5)	2
(5)	水泵体 HOUSING-WATER PUMP	20AL001	1
(6)	水泵盖/COVER-WATER PUMP	20AL004	1
(7)	水泵轴/SHAFT-WATER PUMP	20AL002	1
(8)	机械密封部件/SEAL GP-BASIC	30419-0	1
(9)	垫片/GASKET	20AL005	1
(10)	骨架油封/SEAL-FRAME TYPE	20AL006a	1
(11)	水泵叶轮/IMPELLER-WATER PUMP	20AL003	1
(12)	水泵齿轮 GEAR ASSEMBLY-WATER PUMP	7W0450	1
(13)	深沟球轴承/BEARING	GB/T276-6208/C3	1
(14)	孔用弹性挡圈 RING-RETAINING (INTERNAL)	GB/T893.1-80	1
15	深沟球轴承/BEARING	GB/T276-6207/C3	1
16	垫圈/WASHER	20AL007	1
(17)	六角头螺栓/BOLT	20AL008	1
(18)	垫圈/WASHER	GB/T93-10	2
(19)	六角头螺栓/BOLT	GB/T5783-M10×25	2
(20)	六角锥管螺塞/FILTER	5M6213(1/4-18NPTF)	1

● *1:2W8001 水泵部件中包括标号为(5)……(20)的零部件*1: Water Pump 2W8001 includes parts of Ref.No.1

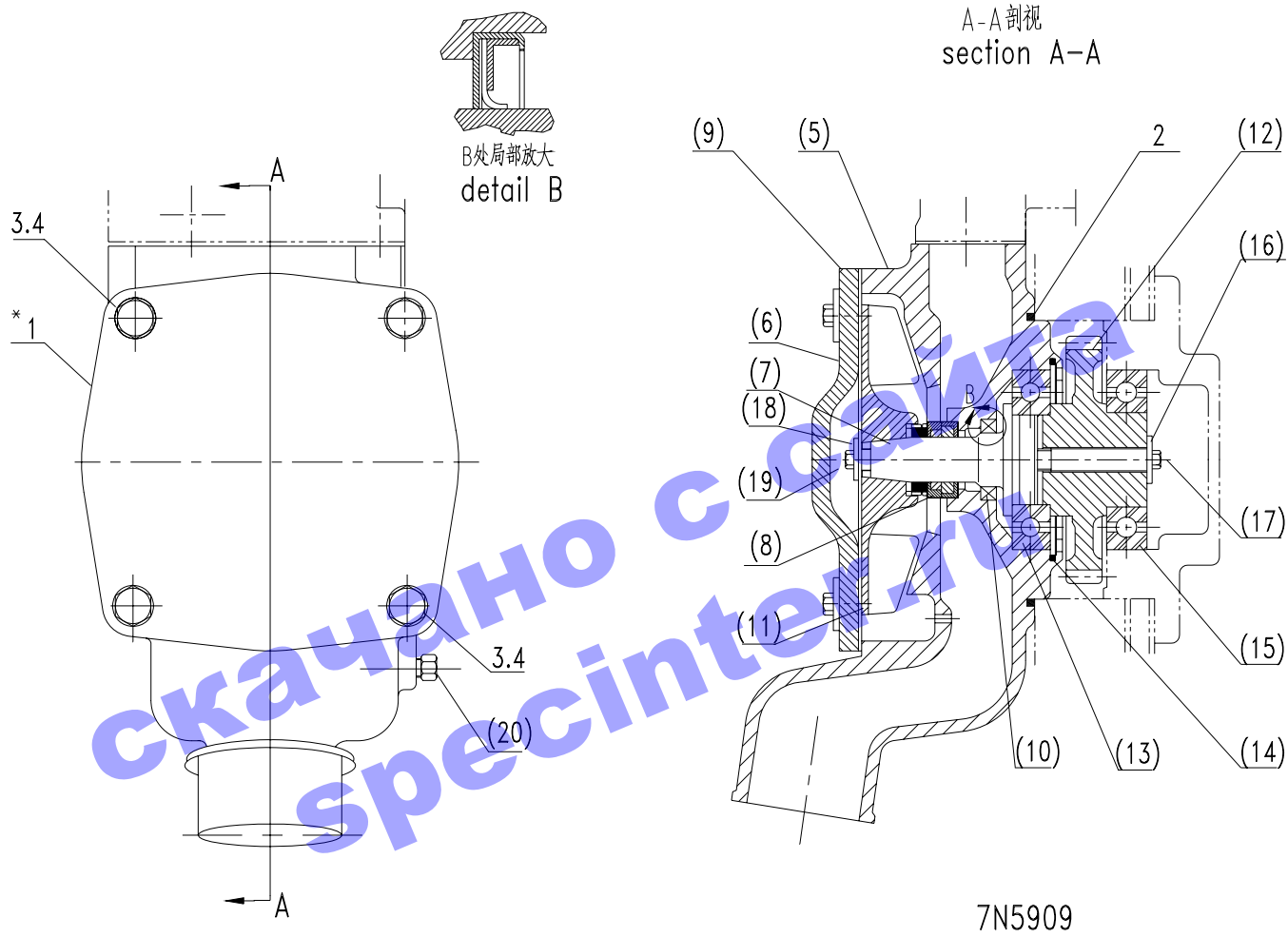
скачано с сайта
specinter.ru

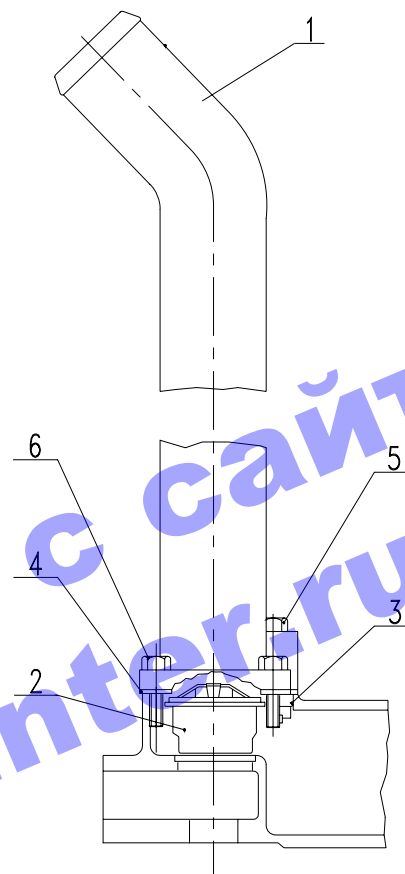

1W7553
22AZ006

图30 调温器组件零部件

FIG.30 REGULATOR & GP-HOUSING

图 30: 调温器组件零部件/ Fig. 30 REGULATOR & GP-HOUSING

标号 Ref. No.	名 称 NAME	件号 PART No.	数量 Quantity
			1W7553
1	出水弯管 ELBOW-REGULATOR HOUSING	1W7529	1
2	调温器/REGUATER GP-HOUSING	1118010	1
3	放气阀部件 VALVE AS. -VENT LINE	8N4485	1
4	垫片/GASKET	7N0944	1
5	六角头螺栓/BOLT	0S1590(3/8-16×50.8)	1
6	六角头螺栓/BOLT	9B7237(3/8-16×31.75)	3

скачано с сайта
specinter.ru

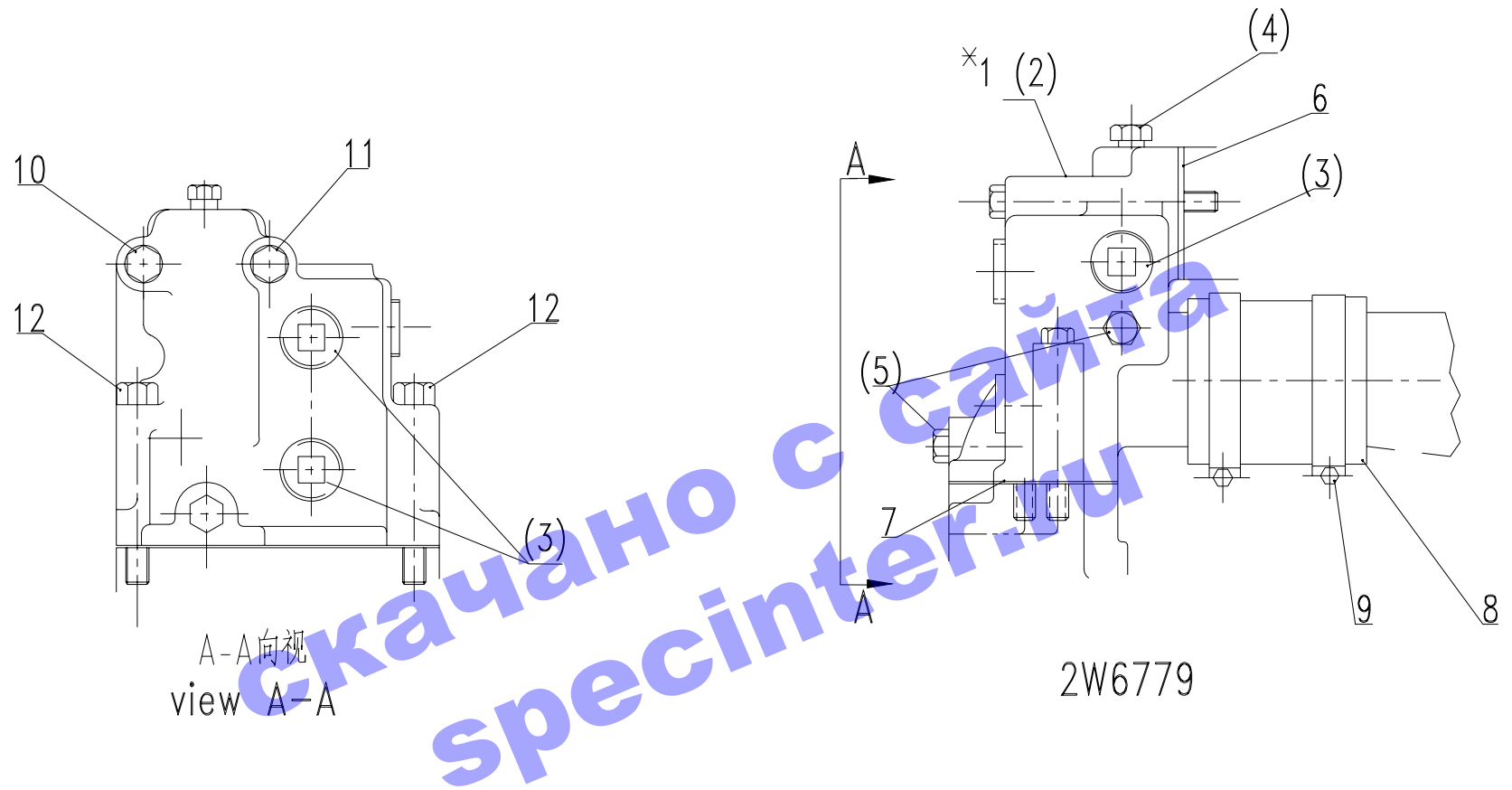

A-A向视
view A-A

2W6779

图31 冷却水管路组件零部件

FIG.31 LINES GP-WATER

图 31:冷却水管路组件零部件/ Fig. 31: LINES GP-WATER

标号 Ref. No.	名称 NAME	件号 PART No.	数量 Quantity
			2W6779
*1	旁通水管路部件/LINES GP	8N4112	1
(2)	分水弯头 ELBOW-OUTLET AND BYPASS	7N0172	1
(3)	内方头锥管螺塞/PLUG	1B5174(3/4-14 NPTF)	2
(4)	六角锥管螺塞/PLUG	3J5390(3/8-18 NPTF)	1
(5)	六角锥管螺塞/PLUG	5M6213(1/4-18 NPTF)	2
6	旁通管垫片/GASKET	2P6132	1
7	垫片/GASKET	7N0200	1
8	连接胶管/HOSE	9L1794	1
9	喉箍/CLAMP	Q/SC1302-52~76	2
10	六角头螺栓/BOLT	0S1590(3/8-16×50.8)	1
11	六角头螺栓/BOLT	0T0065(3/8-1688.9)	1
12	六角头螺栓/BOLT	0S1619(3/8-16×76.2)	2

*1:8N4112 旁通水管部件和 8N4408 旁通水管部件中包括标号为(2)、(3)、(3)、(4)的零件

*1: LINES GP.-Water (By-pASs) 8N4112 includes parts of Ref.No.(2)、(3)、(4)、(5).



图32 喷油管路组件和燃油管路组件零部件

FIG.32 FUEL INJECTION AND DRAIN LINES GP

图 32: 喷油管路组件和燃油管路组件零部件/ Fig. 32: FUEL INJECTION AND DRAIN LINES GP

标号 Ref. No.	名 称 NAME	件号 PART No.	数量 Quantity	
			26AZ201	26BZ203
*1	喷油管路/LINES GP	26AB201	1	
**2	第 1~4 缸高压油管部件 LINES GP-FUEL INJECTION(D)	26AB202	1	
**3	第 5~6 缸高压油管部件 LINES GP-FUEL INJECTION(D)	26AB203	1	
(4)	喷油器部件 NOZZLE AS.-DIRECT INJECTION FUEL VALVE	8N7005	6	
(5)	上油管夹头/CLAMP-FUEL LINE	1W9168	12	
(6)	下油管夹头/CLAMP-FUEL LINE	1W9169	12	
(7)	上油管夹头部件/CLAMP AS.-FUEL LINE	1W9167	3	
(8)	喷油器压板/CLAMP-NOZZLE	7C3469	6	
(9)	第 1 缸高压油管部件 LINE AS.-FUEL INJECTION	26AB204	1	
(10)	第 2 缸高压油管部件 LINE AS.-FUEL INJECTION	26AB205	1	
(11)	第 3 缸高压油管部件 LINE AS.-FUEL INJECTION	26AB206	1	
(12)	第 4 缸高压油管部件 LINE AS.-FUEL INJECTION	26AB207	1	
(13)	第 5 缸高压油管部件 LINE AS.-FUEL INJECTION	26AB208	1	
(14)	第 6 缸高压油管部件 LINE AS.-FUEL INJECTION	26AB209	1	
(15)	支架/BACKET	4P2578	1	
(16)	支架焊接部件/BACKET AS.	7C7614	1	
(17)	支架焊接部件/BACKET AS.	1229405	1	
(18)	固定钢板/CLAMP	9Y7524	1	
19	六角螺母/NUT	3S2713(3/8-24)	3	
20	平垫圈/WASHER	5M2894(10.2×12.5×2.5)	2	

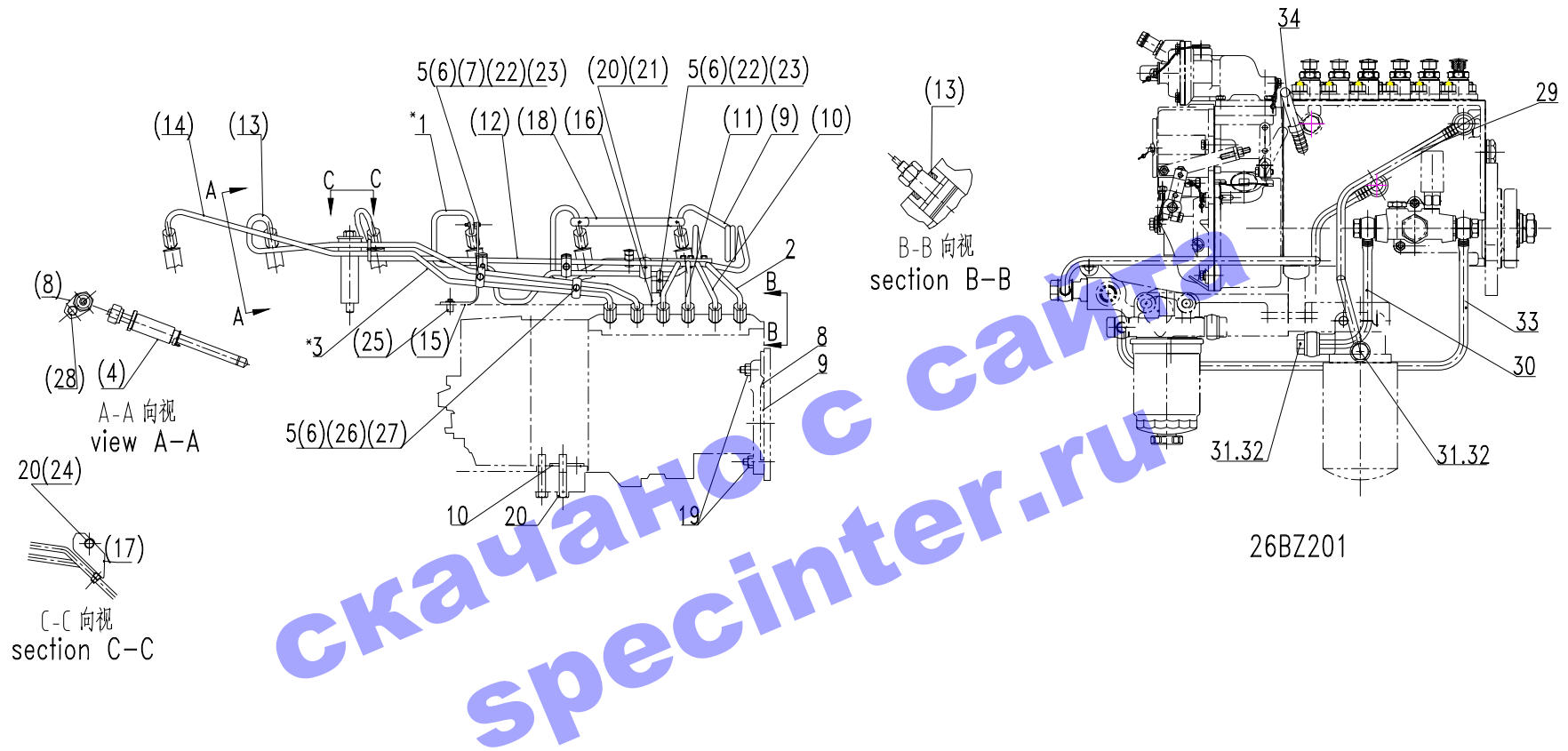
*1:1W3008 喷油管路部件中包括标号为**2、**3、(4)~(6)、(7)、(8)、(15)、(21)、(22)、(24)、(25)、(28) 等零部件

*1: LINES GP.-Fuel Injection1W3008 includes parts of Ref.No.**2、**3、(4)~(8)、(15)、(21)、(22)、(24)、(25)、(28) .

**2:4P9330 第 1~4 缸高压油管部件中包括标号为(5)~(7)、(9)~(12)、(16)、(18)、(22)、(23)、(26)、(27) 等零部件

**2: LINES GP.-Fuel Injection 4P9330 includes parts of Ref.No.(5)~(7)、(9)~(12)、(16)、(18)、(22)、(23)、(26)、(27).

**3:4P9331、4P9332 第 5~6 缸高压油管部件中包括标号为(5)··· (7)、(13)、(14)、(17)、(22)、(26)、(27) .等零部件

**3: LINES GP.-Fuel Injection 4P9331 includes parts of Ref.No.(5)··· (7)、(13)、(14)、(17)、(22)、(26)、(27) .

图 32: 喷油管路组件和燃油管路组件零部件/ Fig. 32: FUEL INJECTION AND DRAIN LINES GP

标号 Ref. No.	名 称 NAME	件号 PART No.	数量 Quantity	
			26AZ201	26BZ203
(21)	六角头螺栓/BOLT	0S1591(3/8-16×38.1)	1	
(22)	自锁螺钉/LOCK	9N3388(10-24×19.05)	5	
(23)	平垫圈/WASHER	4B4274(5.5×13.0×1.2)	4	
(24)	六角头螺栓/BOLT	0T0055(3/8-16×107.95)	1	
(25)	六角头螺栓/BOLT	2P3200(3/8-16×19.05)	1	
(26)	带槽六角螺钉/BOLT	26AL101	8	
	带槽六角螺钉部件/BOLT	5P4939(10-24×15.88)	8	
(27)	标准型弹簧垫圈/SPRING WASHER	GB/T93-5	8	
(28)	12 角头螺栓/BOLT	1T0416(5/16-18×19.05)	6	
29	喷油泵进油管/PUMP PIPE LINE	26BB201		1
30	输油泵出油管/OUTLET LINE	26BB203		1
31	铰接螺栓/BOLT	Q/SC642.1-01-M12×1.25×25		2
32	复合垫圈/GASKET	Q/SC1294-12		4
33	输油泵进油管/INLET LINE	26BB202		1
34	喷油泵回油管焊接部件/PIPE AS.	26BB206		1

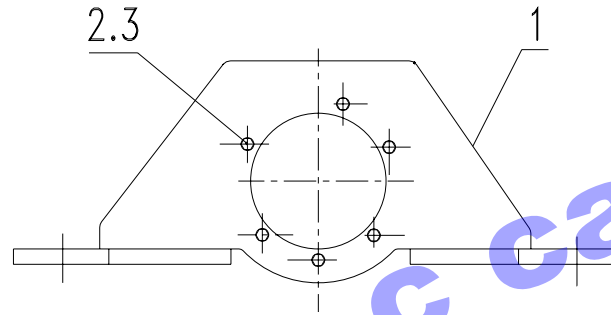
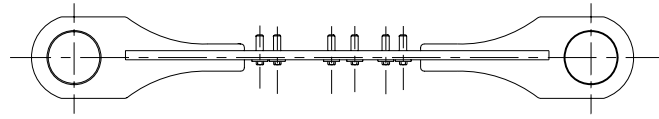

33AZ012

скачано с сайта
specinter.ru

图33 发动机支架组件零部件

FIG.33 SUPPORT GP-ENGINE

图 33: 发动机支承组件、飞轮壳支架组件和发动机安装紧固组件零部件
 Fig. 33: ENGINE SUPPORT、FLYWHEEL HOUSING SUPPORT AND BOLT MTG GP

标号 Ref. No.	名 称 NAME	件号 PART No.	数量 Quantity
			33AZ012
1	发动机前支架焊接部件 SUPPORT AS. -ENGINE	33AB012A	1
2	六角头螺栓/BOLT	0S1585(1/2-13×38.1)	6
3	垫片/WASHER	5P8245(13.5×25.5×3.0)	6

скачано с сайта
 specinter.ru

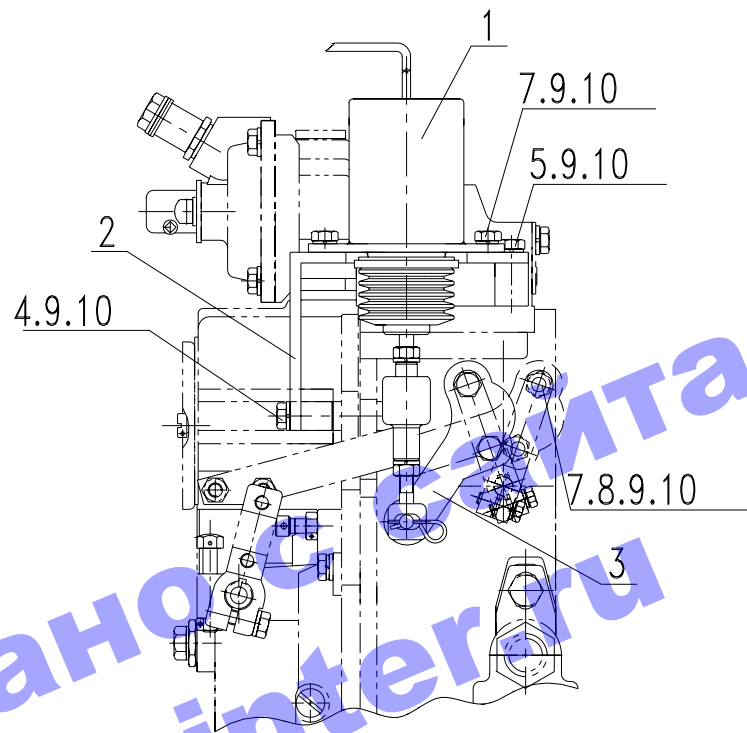

59AZ212

图34 电磁切断器组件零部件

FIG.34 SHUT-OFF GP-ELECTRICAL

图 34: 电磁切断器组件零部件/ Fig. 34: SHUT-OFF GP-ELECTRICAL

标号 Ref.	名称 NAME	件号 PART No.	数量 Quantity
			59AZ212
1	停机电磁铁/SOLENOID(ENERGIZED TO SHUT DOWN)	59AL214	1
2	电磁铁支架焊接件/BRACKET	59AL202	1
3	停油手柄铆接件/HANDLE AS.	59AL205	1
4	内六角圆柱头螺钉/BOLT	GB/T70-M6×40	1
5	六角头螺栓/BOLT	GB/T5782-M6×40	2
6	六角头螺栓/BOLT	GB/T5783-M6×16	2
7	六角头螺栓/BOLT	GB/T5783-M6×20	2
8	六角螺母/NUT-FULL	GB/T6170-M6	2
9	标准弹簧垫圈/WASHER-SPRING	GB/T93-6	9
10	平垫圈/WASHER	GB/T97.1-6-200HV	9

скачано с сайта
specinter.ru



图.35前齿壳组件、前齿壳盖板组件和前齿壳紧固组件零部件
 FIG.35 FRONT HOUSING、COVER AND FASTENER GP

图 35: 前齿壳组件、前齿壳盖板组件和前齿壳紧固组件零部件

Fig. 35: FRONT HOUSING、COVER AND FASTENER GP

标号 Ref. No	名称 NAME	件号 PART No.	数量 Quantity		
			8N0303	2P6528	8N0872
*1	前齿壳部件/HOUSING AS. -FRONT	6I0923	1		
(2)	前齿壳/HOUSING-FRONT	4P9863	1		
(3)	过盈配合双头螺栓 STUD (TYPE 1)	9X2485	6		
*4	过渡板部件/PLATE AS. -FRONT	1W7816	1		
(5)	过渡板/PLATE-FRONT	1W7110	1		
(6)	过盈配合双头螺栓 STUD (TYPE 1)	6H0192	3		
(7)	六角头锥管螺塞/PLUG-PIPE	5M6214(1/8-27 NPTF)	1		
8	过渡板密封垫片 GASKET-FRONT PLATE	8N0110	1		
9	前齿壳垫片/GASKET-FRONT CORER	1W3900	1		
10	喷油泵齿轮孔盖板 COVER-FRONT HOUSING	9N5769		1	
11	喷油泵齿轮孔盖板垫片 GASKET-FRONT HOUSING COVER	6N7887		1	
12	六角螺母/NUT-FULL	3S2713(3/8-24)		6	
13	平垫圈/WASHER-HARD	8M9024(10.2×22.5×5.0)		6	
14	六角头螺栓/BOLT	3B1915(3/8-16×34.92)		3	
15	平垫圈/WASHER	5M2894(10.2×18.5×2.5)		3	
16	六角头螺栓/BOLT	0S1566(5/8-11×38.1)		2	
17	平垫圈/WASHER	5P8247(17.0×32.0×3.5)		2	
18	水泵盖板/COVER	1W4542		1	
19	水泵垫片/GASKET	2P0220		1	
*20	O 型橡胶密封圈/SEAL-O-RING	5F3106(126.59×3.53)		1	
*21	B 型传动泵孔盖板/COVER	S7N8374		1	
*22	六角头螺栓/BOLT	0S1566(5/8-11×38.1)		2	
*23	平垫圈/WASHER	5P8247(17.0×32.0×3.5)		2	

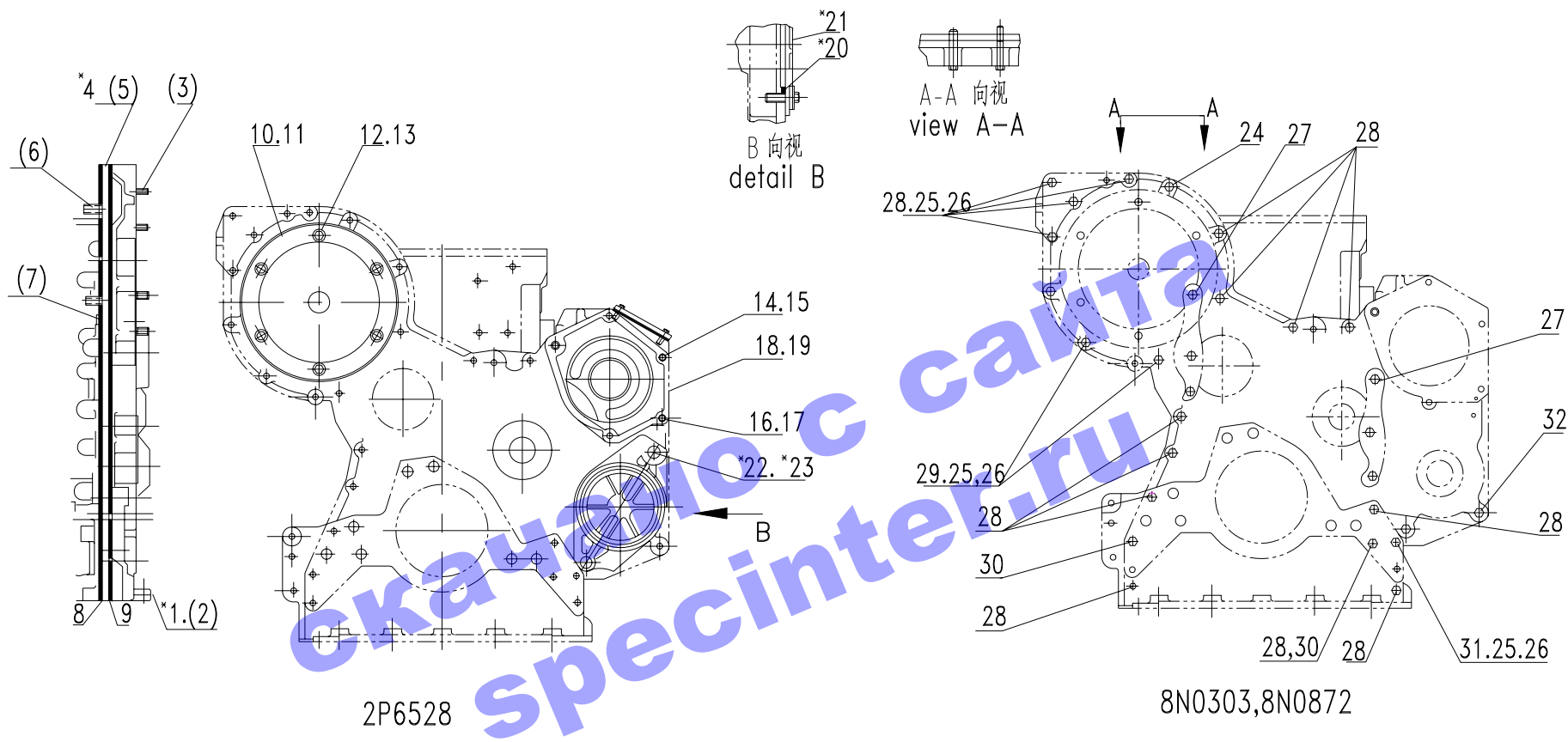
图 35: 前齿壳组件、前齿壳盖板组件和前齿壳紧固组件零部件
 Fig. 35: FRONT HOUSING、COVER AND FASTENER GP

标号 Ref. No.	名称 NAME	件号 (备注) PART No. (NOTE)	数量 Quantity		
			8N0303	2P6528	8N0872
24	六角头螺栓/BOLT	1C2251(3/8-16×47.62)			2
25	平垫圈/WASHER-HARD	5M2894(10.2×18.5×2.5)			8
26	六角螺母/HUT	6V8801(3/8-16)			8
27	六角头螺栓/BOLT	308535(3/8-16×22.22)			6
28	六角头螺栓/BOLT	0L2070(3/8-16×57.15)			15
29	六角头螺栓/BOLT	0L2070(3/8-16×57.15)			2
30	六角头螺栓/BOLT	0L2070(3/8-16×57.15)			2
31	六角头螺栓/BOLT	0L2070(3/8-16×57.15)			1

*1: 6I0923 前齿壳部件中包括标号为 (2)、(3) 的零件。

*1: Housing AS.-Front 6I0923 includes parts of Ref.No.(2)、(3).

*20、*21、*22、*23 标号的零件仅用于发动机试验和运输，当泵和安装组件装配后即予以拆除。

*20、*21、*22、*23 Parts only be used in test and transport, backout these when pump ASsembled.

*4: 1W7816 过渡板部件中包括标号为 (5)、(6)、(7) 的零件。

*4: PLATE AS.-Front 1W7816 includes parts of Ref.No.(5)、(6)、(7).

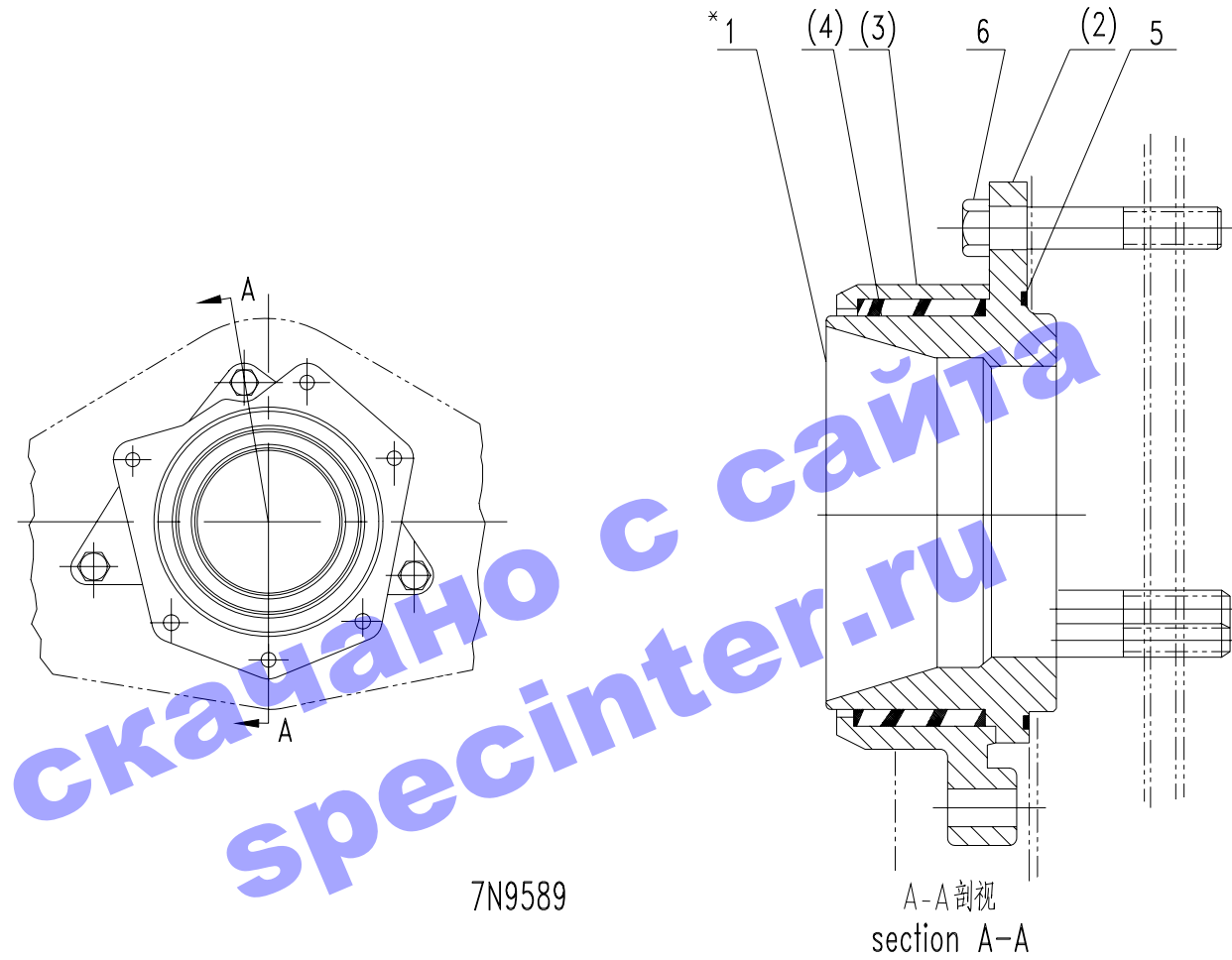

7N9589

图36 前油封座组件零部件

FIG.36 TRUNNION GP

图 36: 前油封座组件 (耳轴) 零部件/ Fig. 36: TRUNNION GP

标号 Ref. No	名称 NAME	件号 PART No.	数量 Quantity
			7N9589
*1	耳轴部件/TRUNNION AS.	1W1219	1
(2)	耳轴/TRUNNION	8N0081	1
(3)	外支承/SUPPORT-ENGINE	1W1217	1
(4)	橡胶减振圈/RING	2P1487	1
5	O 型密封圈/SEAL-O-RING	2P1692(133.02×2.62)	1
6	六角头螺栓/BOLT	0L1329(1/2-13×76.2)	3

*1:2W6757 耳轴部件中包括标号为 (2)、(3)、(4) 的零件.

*1: Trunnion AS. 2W6757 includes parts of Ref..No.(2)、(3)、(4) respectively.

скачано с сайта
specinter.ru



图37 气门机构组件, 气缸盖罩壳组件, 通风帽组件和通气管组件零部件
 FIG.37 VALVE MECHANISM、COVER、BREATHER AND FUMES DISPOSAL GP

图 37: 气门机构组件、气缸盖罩壳组件、通风帽组件和通气管组件零部件

Fig. 37: VALVE MECHANISM、COVER、BREATHER AND FUMES DISPOSAL GP

标号 Ref. No.	名称 NAME	件号 PART No.	数量 Quantity			
			7N8026	8N4745	1P4244	84DZ003
*1	配气机构部件 MECHANISM GP. -VALVE(A) (BASIC)	8N4576	1			
**2	摇臂轴部件/ARM SHAFT AS. -ROCKER	8N3252	1			
(3)	摇臂座 BRACKET-ROCKER ARM SHAFT	5S5878	4			
(4)	摇臂轴弹簧/SPRING	4B4910	5			
(5)	平垫圈/WASHER	9H1110(19.0×31.5×1.5)	12			
**6	摇臂座部件 BRACKET ASSEMBLY-ROCKER ARM SHAFT	8S1499	1			
**7	进气门摇臂部件/ARM GP-V ROCKER	8N3327(9Y1519)	6			
(8)	进气门摇臂机加工部件 ARM GP-V ROCKER	9Y1521	6			
**9	排气门摇臂部件/ARM GP-V ROCKER	8N3325(9Y1515)	6			
(10)	排气门摇臂机加工部件 ARM GP-V ROCKER	9Y1516	6			
(11)	气门调节螺钉 SCREW-VALVE ROCKER AD JUSTING	5S5917	12			
(12)	六角螺母/NUT-FULL	3S2713(3/8-24)	12			
(13)	平垫圈/WASHER	9M9886(19.0×31.5×0.8)	2			
(14)	弹簧片/SPRING	9H1112	2			
(15)	小卡环/RING-RETAINING (EXTERNAL)	9H1113				
(16)	O型密封圈/SEAL-O RING	8M4448(15.47×3.53)	1			
(17)	气缸盖螺栓/BOLT	1B7709(5/8-11×203.2)	1			
(18)	平垫圈/WASHER-HARD	2S0736(17.0×27.0×3.5)	1			
(19)	摇臂座/BRACKET-ROCKER ARM SHAFT	7N8015	1			
(20)	摇臂轴(6缸)/SHAFT AS. -ROCKER ARM	8N3251	1			
(21)	螺塞/PLUG	84AL002	2			
(22)	圆柱销/DOWEL	5M4606(4.605×57.0)	1			
(23)	第一档摇臂座 BRACKET-ROCKER ARM SHAFT	8S1498	1			
(24)	圆柱销/DOWEL	1L5072(4.605×15.75)	1			

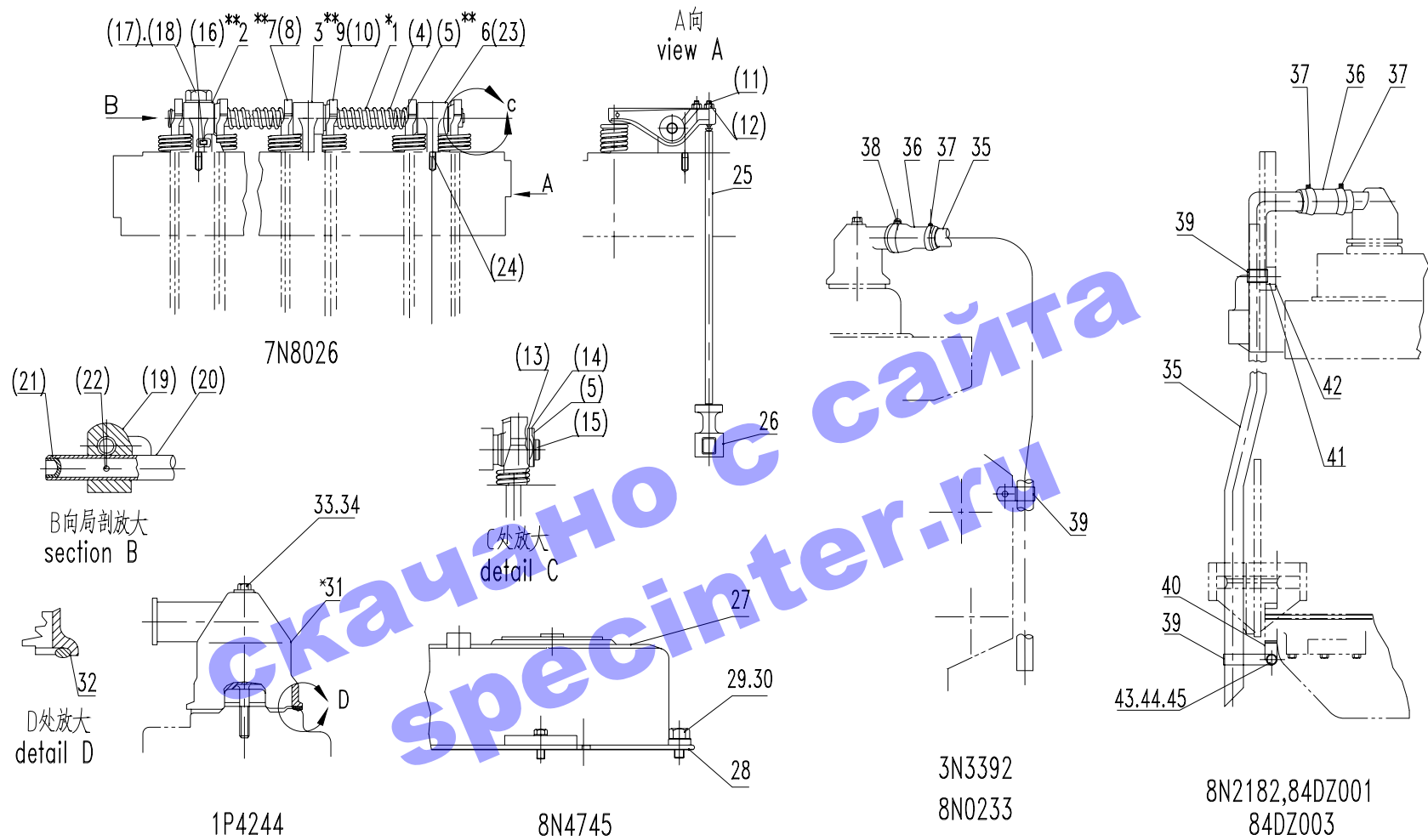
图 37: 气门机构组件、气缸盖罩壳组件、通风帽组件和通气管组件零部件

Fig. 37: VALVE MECHANISM、COVER、BREATHER AND FUMES DISPOSAL GP

标号 Ref. No.	名称 NAME	件号 PART No.	数量 Quantity			
			7N8026	8N4745	1P4244	84DZ003
25	气门推杆部件/ROD-VALVE PUSH	5S5918	12			
26	气门挺柱/LIFTER-VALVE	7S3161	12			
27	气缸盖罩壳部件 COVER AS. -CYLINDER HEAD	2W1086		1		
28	气缸盖罩壳垫片 GASKET-CYLINDERHEADCOVER	1331247		1		
29	六角头螺栓/BOLT	0S1617(5/16-18×19.05)		15		
30	弹簧垫片/LOCKWASHER-5/16	3B4505(7.98×14.58×2.46)		15		
*31	通风帽部件/CAP AS. -BREATHE	2W9162			1	
32	O型密封圈/SEAL-O-RING	4L9564(81.92×5.33)			1	
33	六角头螺栓/BOLT	3H3243(5/16-18×120.65)			1	
34	平垫圈/WASHER-HARD	9N0869(8.8×25.5×2.0)			1	
35	通气管/TUBE-FUMES DISPOSAL	84DL003				1
36	连接软管/HOSE	1N4102				
37	喉箍/CLAMP	Q/SC1302-21~44				
38	喉箍/CLAMP	Q/SC1302-27~51				1
39	夹圈/CLIP	1S4557(1.5/0.8)				
40	夹圈/CLIP	84DL002				1
41	隔圈/SPACER	5B0546				
42	衬套/BOSS	8B9725				
43	六角头螺栓/BOLT	5P2228(1/2-13×25.4)				
44	平垫圈/WASHER-HARD	8T4223(13.5×25.5×3.0)				
45	六角螺母/NUT-FULL	6V8188(1/2-13)				
46	六角头螺栓/BOLT	0T0573(3/8-16×69.85)				

图 37: 气门机构组件、气缸盖罩壳组件、通风帽组件和通气管组件零部件

Fig. 37: VALVE MECHANISM、COVER、BREATHER AND FUMES DISPOSAL GP

标号 Ref. No.	名称 NAME	件号 PART No.	数量 Quantity			
			7N8026	8N4745	1P4244	84DZ003
47	平垫圈/WASHER	5M2894(10.2×18.5×2.5)				
(48)	轴用弹性挡圈 RING-RETAINING (INTERNAL)	GB/T894.1-18	2			
49	卡簧/SPRING	161-1033				

*1:8N4576 配气机构部件中包括标号为**2、(3)、(4)、(5)、**6、**9、(13)……(18)的零部件。

*1: Mechanism GP.-VALVE (A) 8N4576 includes parts of Ref.No.**2、(3)、(4)、(5)、**6、**9、(13)…(18).

**2: 8N3252 摇臂轴部件中包括标号为(19)……(22)的零件。

**2: Rocker SHAFT GP. 8N3252 includes parts of Ref.No.(19)…(22).

**6: 8S1499 摇臂座部件中包括标号为(23)、(24)的零件。

**6: BRACKET ASsembly-Rocker Arm SHAFT 8S1499 includes parts of Ref.No.(23)、(24).

**7: 8N3327 (9Y1519) 进气门摇臂部件中包括标号为(8)、(11)、(12)的零部件; 9Y1521 进气门摇臂机加工部件中包括 9Y1520 进气门摇臂和 7W6773 摇臂衬套。

**7: Arm GP.-V Rocker 8N3327 (9Y1519) includes parts of Ref.No.(8)、(11)、(12); Arm GP.-V Rocker 9Y1521 includes Arm GP.-V Rocker 9Y1520 and Lining-Arm Rocker 7W6773.

**9: 8N3325 (9Y1515) 排气门摇臂部件中包括标号为(10)、(11)、(12)的零部件; 9Y1516 排气门摇臂机加工部件中包括 9Y1517 排气门摇臂和 7W6773 摇臂衬套。

**9: Arm GP.-V Rocker 8N3325 (9Y1515) includes parts of Ref.No.(10)、(11)、(12); Arm GP.-V Rocker 9Y1516 includes Arm GP.-V Rocker 9Y1517 and Lining-Arm Rocker 7W6773.

**31: S2W9162 通风帽部件中包括 84CL002 通风帽体, 84CL002 通风帽架, 84CL003 通风帽滤芯。

**31: Breather GP.S2W9162 includes Breather Body 84CL001、Breather BRACKET 84CL002 and Breather Element 84CL003.



图38 燃油滤清器组件零部件
FIG.38 FILTER GP-SECONDARY

图 38: 燃油滤清器组件零部件/ Fig. 38: FILTER GP-SECONDARY

标号 Ref. No.	名称 NAME	件号 PART No.	数量 Quantity
			85AZ203
1	滤清器部件/FUEL FILTER AS.	1W8633	
2	滤清器座机加工部件 BASE AS. -FUEL FILTER	7N9519	
	燃油滤清器支架/BRACKET	85AL201b	1
3	0 型密封圈/SEAL-O-RING	3J1907(11.89×1.98)	
4	90° 弯管接头/CONNECTOR-ELBOW (90°)	307947	
5	管子部件/TUBE AS. -SECONDARY FUELFILTER	4W9057	
6	垫片/GASKET-FILTER BASE	7N9520	
7	六角头螺栓/BOLT	6B4198(1/4-20×106.36)	
8	垫圈/WASHER-HARD	5P0537(7.2×14.5×2.0)	
9	六角头螺栓/BOLT	GB/T5783-M10×25	1
10	垫圈/WASHER-HARD	5M2894(10.2×18.5×2.5)	1
	垫圈/WASHER-HARD	GB/T97.2-10-200HV-Y	1
11	六角头螺栓/BOLT	0T0055(3/8-16×107.95)	1
12	六角头螺栓/BOLT	GB/T5783-M8×30	2
13	垫圈/WASHER-HARD	GB/T97.1-8-200HV-Y	2
14	螺母/NUT	GB/T6170-M8	2
15	油水分离器装配部件/SEGREGATOR	D00-034-01	1
16	燃油滤清器组件/FUEL FILTER	D638-000-02	1
	六角法兰面螺栓/BOLT	Q/SC622-M12×55	2

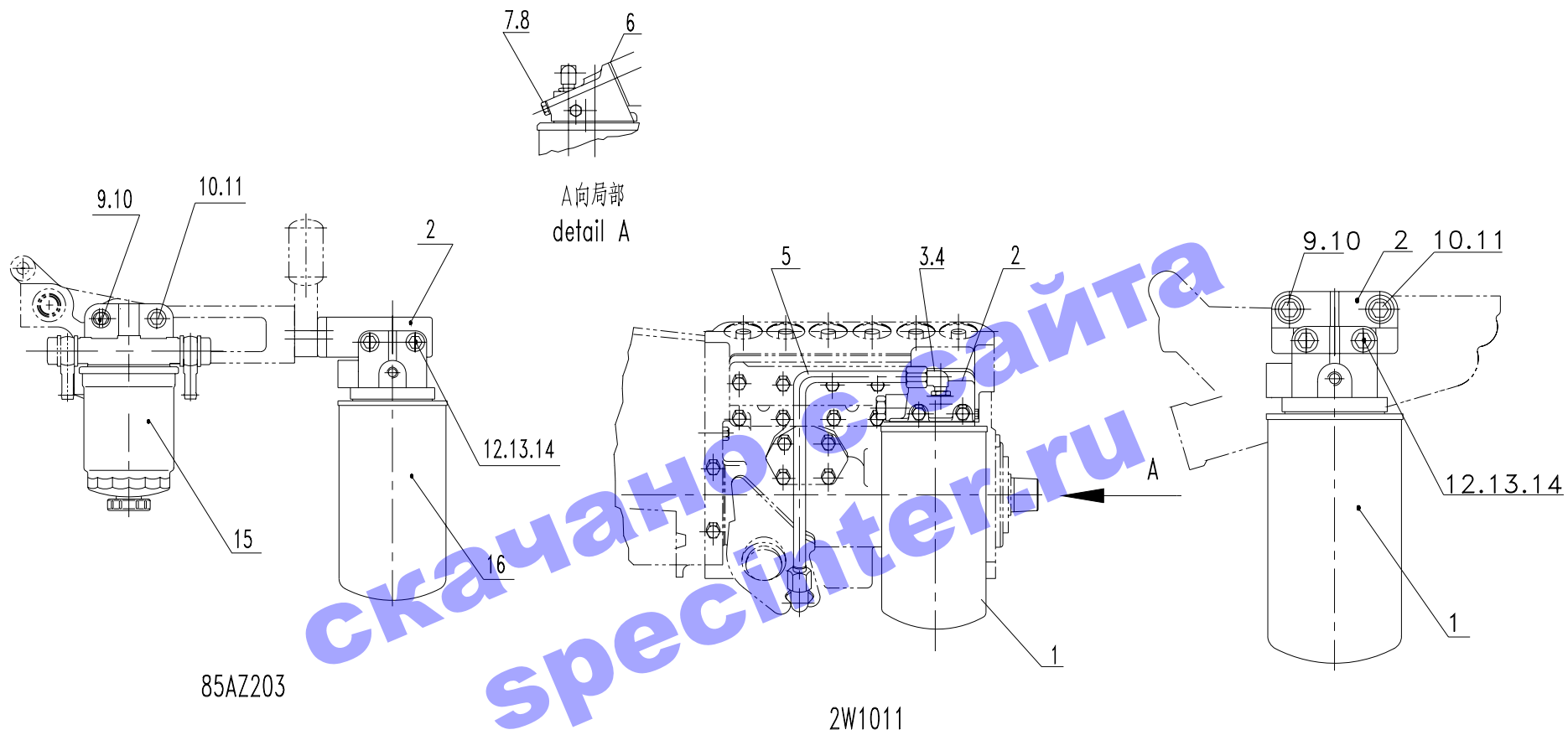

图39 随机工具组件零部件

FIG.39 TOOLS GP

图 39: 随机工具组件零部件/ Fig. 39: TOOLS GP

标号 Ref. No	名 称 NAME	件号 PART No.	数量 Quantity	
			49AZ002	49AZ202
1	旋装式滤清器装拆工具部件 TOOL(FILTER)	49AB001		1
2	喷油泵定时销 TIMING PIN (PUMP-FUEL INJECTION)	49AL201		1
3	飞轮定时螺栓 FLYWHEEL BOLT (TIMING)	49AL003		1
4	气门间隙量规/GAUGE	49AL013		1
5	随机工具组件 TOOLS GP			1

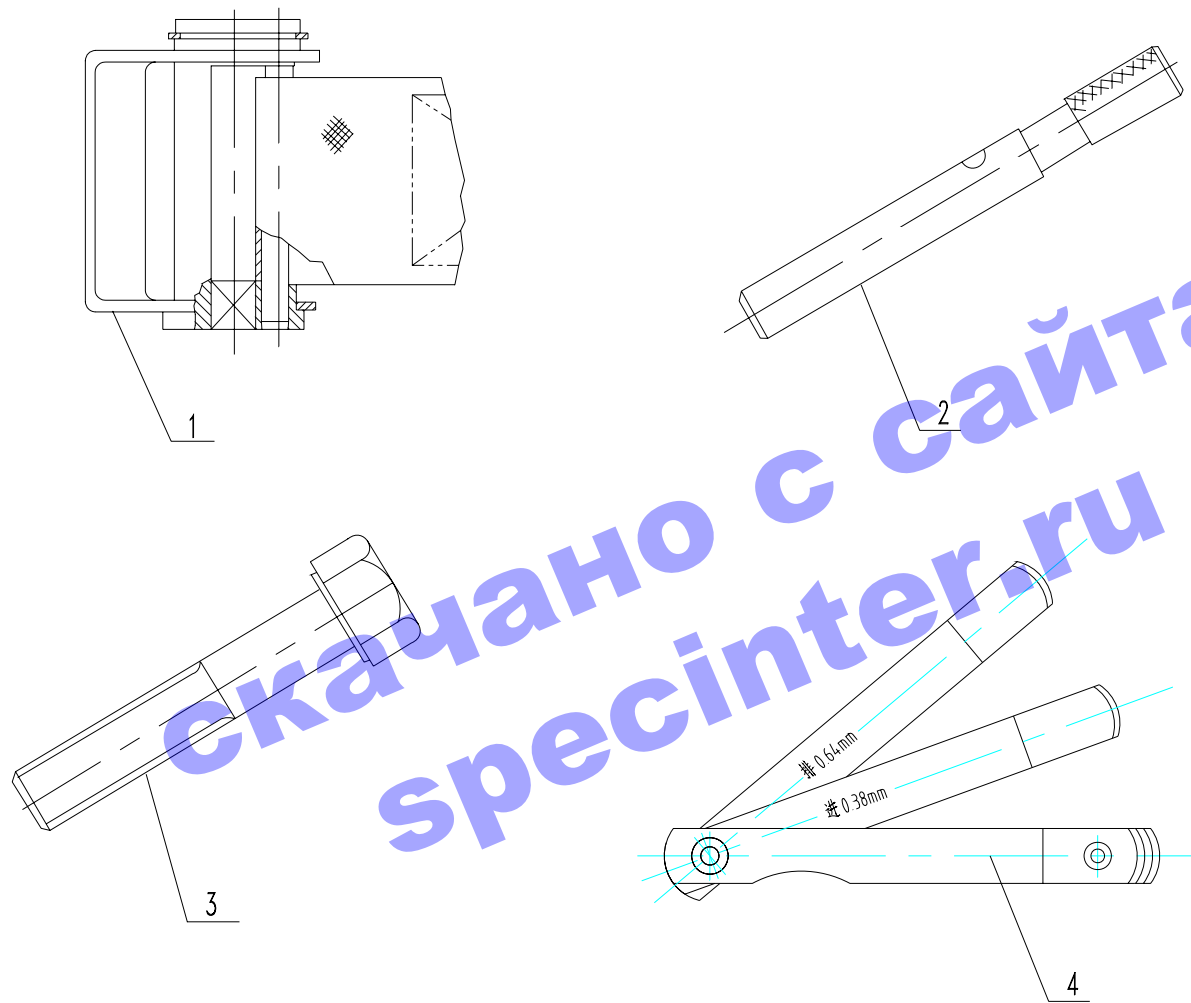
скачано с сайта
specinter.ru

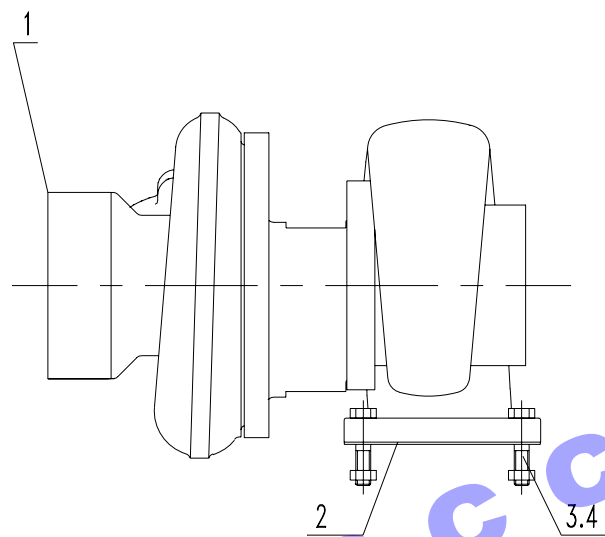

скачано с сайта
specinter.ru

38AZ005

图40增压器组件零部件
FIG.40 TURBOCHARGER GP

图 40: 增压器组件零部件/ Fig. 40: TURBOCHARGER GP

标号 Ref. No	名 称 NAME	件号 PART No.	数量 Quantity
			38AZ005
1	TD08H 型增压器 TD08H TURBOCHARGER GP	38AB006	1
2	涡轮进口垫片 GASKET-TURBOCHARGER	1S4295	1
3	耐热螺栓/BOLT-HIGH TEMP	7L3195(3/8-16×44.45)	4
4	锁紧螺母/LOCKNUT	2N2766(3/8-16)	4

скачано с сайта
specinter.ru

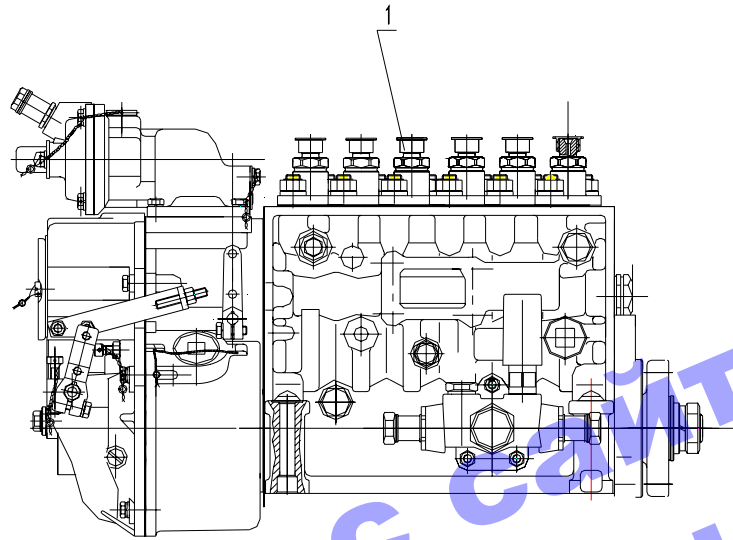

скачано с сайта
specinter.ru

图41: 喷油泵调速器组件和调速器控制件零部件

Fig.41: PUMP & CONTROL GP-GOV

图 41： 喷油泵调速器组件和调速器控制件零部件 Fig. 41: PUMP & CONTROL GP-GOV

标号 Ref. No.	名称 NAME	件号 PART No.	数量 Quantity
			P10Z005
1	喷油泵调速器组件/PUMP GP-GOV&FUEL INJECTION	P10Z005-000WX	1

скачано с сайта
specinter.ru

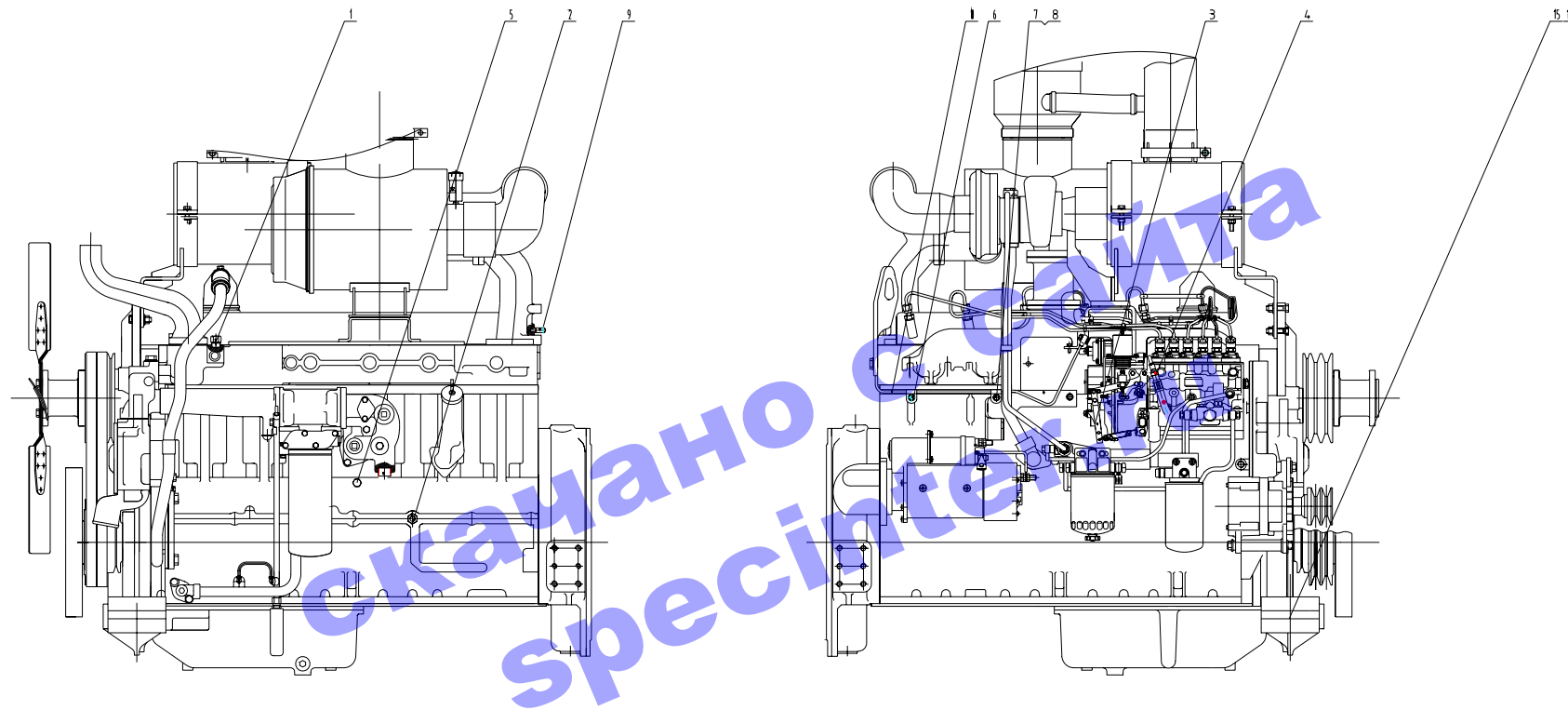

图42：变型配套及其它组件
Fig.42: APPLICATION GP

图 42: 变型配套及其它组件/ Fig. 42: APPLICATION GP

标号 Ref. No.	名 称 NAME	件号 PART No.	数量 Quantity
			00AZ214
1	水温表接头/CONNECTOR	00AL038	1
2	机油压力表接头/CONNECTOR	00AL089	1
3	调速器控制手柄/HANDLE	D26-128-03	1
4	燃油进油接头/CONNECTOR	00AL104	1
5	放水阀/VALVE	00AL095	1
6	夹子/CILP	2B2404	2
7	六角头螺栓/BOLT	2H3755(5/16-18×15.88)	2
8	平垫圈/WASHER	9M1974(8.8×16.0×2.0)	2
9	37° 扩口 90° 弯管接头 ELBOW-90° -37° FLARED	6K1972	1
10	空燃比通气管部件/TUBE AS.	00AB205	1
(11)	管接螺母/NUT	8L3161	1
(12)	钢管/TUBE	5P0077	1
(13)	护套/SLEEVE	8L3162	1
(14)	管接头体/CONNECTOR	Q/SC642.1-02-10.2	1
15	套筒/SLEEVE	4N4539	2
16	前弹性支承部件/MOUNT AS.	6N3256	2